

Environmental Impact Assessment for Wan Chai Development Phase II and Central-Wan Chai Bypass

Updated Environmental Monitoring and Audit Manual

For

Central-Wan Chai Bypass including its Road Tunnel and Slip Roads

under Environmental Permit No. EP-364/2009/A

(December 2010)

Environmental Impact Assessment for Wan Chai Development Phase II and Central-Wan Chai Bypass



Updated Environmental Monitoring and Audit Manual

For

Central-Wan Chai Bypass including its Road Tunnel and Slip Roads

under Environmental Permit No. EP-364/2009/A

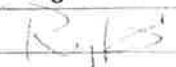
(December 2010)

		Name	Signature
Certified by:	Environmental Team Leader	Raymond Dill	
Verified by:	Independent Environmental Checker	David Yeung	

CONTENTS

1. INTRODUCTION
 - 1.1 Purpose of the Manual
 - 1.2 Project Background
 - 1.3 Environmental Monitoring and Audit Requirements
 - 1.4 Project Organisation

 2. AIR QUALITY
 - 2.1 Introduction
 - 2.2 Air Quality Parameters
 - 2.3 Monitoring Equipment
 - 2.4 Laboratory Measurement / Analysis
 - 2.5 Monitoring Locations
 - 2.6 Baseline Monitoring
 - 2.7 Impact Monitoring of Construction Air Quality Impact
 - 2.8 Environmental Quality Performance Limits
 - 2.9 Event and Action Plan for Construction Air Quality
 - 2.10 Construction Dust Mitigation Measures
 - 2.11 Tunnel Emission

 3. NOISE
 - 3.1 Introduction
 - 3.2 Noise Parameters
 - 3.3 Monitoring Equipment
 - 3.4 Baseline Monitoring
 - 3.5 Impact Monitoring of Construction Noise Impact
 - 3.6 Event and Action Plan for Construction Noise
 - 3.7 Noise Mitigation Measures
 - 3.8 Operational Phase Noise Monitoring

 4. WATER QUALITY
 - 4.1 Introduction
 - 4.2 Water Quality Impacts Mitigation Measures during Construction Phase
 - 4.3 Water Quality Impacts Mitigation Measures during Operational Phase

 5. WASTE MANAGEMENT
 - 5.1 Introduction
 - 5.2 Waste Control and Mitigation Measures

 6. LANDSCAPE AND VISUAL
 - 6.1 Introduction
 - 6.2 Monitoring Details
 - 6.3 Baseline Monitoring
 - 6.4 Event/Action Plan for Landscape and Visual Works
 - 6.5 Mitigation Measures

 7. (NOT USED)

 8. (NOT USED)
-

- 9. SITE ENVIRONMENTAL AUDIT
 - 9.1 Site Inspections
 - 9.2 Compliance with Legal and Contractual Requirements
 - 9.3 Environmental Complaints

- 10. REPORTING
 - 10.1 General
 - 10.2 Baseline Monitoring Report
 - 10.3 Monthly EM&A Reports
 - 10.4 Quarterly EM&A Summary Reports
 - 10.5 Final EM&A Review Reports
 - 10.6 Data Keeping
 - 10.7 Interim Notifications of Environmental Quality Limit Exceedances

LIST OF FIGURES

- Figure 1.1 Designated Project 1: Central-Wan Chai Bypass (CWB) Including Its Road Tunnel and Slip Roads
- Figure 1.2 Project Organisation
- Figure 2.1 Locations of Air Quality Monitoring Stations
- Figure 3.1 Locations of Noise Monitoring Stations
- Figure 6.1a Baseline Landscape Resources during Construction
- Figure 6.1b Baseline Landscape Resources during Operation
- Figure 6.2a Baseline Landscape Character Areas during Construction
- Figure 6.2b Baseline Landscape Character Areas during Operation
- Figure 6.3a Key VSRs and Primary Zone of Visual Influence during Construction
- Figure 6.3b Key VSRs and Primary Zone of Visual Influence during Operation
- Figure 6.3c Key VSRs and Secondary Zone of Visual Influence

LIST OF APPENDICES

- Appendix A Implementation Schedule
- Appendix B Sample Data Sheet for Air Quality and Noise Monitoring
- Appendix C Sample Template for the Interim Notification
- Appendix D Operation Stage Traffic Noise Monitoring – Field Survey Record Sheet
- Appendix E Terms of Reference and Details for the ENPC and CLG
- Appendix F Proposal for Real-time Noise Monitoring System
- Appendix G Construction Programmes of Works Contracts

CONTENTS

1	INTRODUCTION.....	1-1
1.1	Purpose of the Manual.....	1-1
1.2	Project Description	1-1
1.3	Environmental Monitoring and Audit Requirements.....	1-2
1.4	Project Organisation	1-5
1.5	Latest Project Information.....	1-9

LIST OF FIGURES

- Figure 1.1 Designated Project 1: Central – Wan Chai Bypass (CWB) Including Its Road Tunnel and Slip Roads
- Figure 1.2 Project Organization

LIST OF APPENDICES

- Appendix E Terms of Reference and Details for the ENPC and CLG
- Appendix G Construction Programmes of Works Contracts

1 INTRODUCTION

1.1 Purpose of the Manual

1.1.1 The purpose of this Environmental Monitoring and Audit (EM&A) Manual is to guide the set up of an EM&A programme to ensure compliance with the Environmental Impact Assessment (EIA) study recommendations, to assess the effectiveness of the recommended mitigation measures and to identify any further need for additional mitigation measures or remedial action. This Manual outlines the monitoring and audit programme for the construction and operation of the works under the proposed Central-Wan Chai Bypass (CWB) including its road tunnel and slip roads. It aims to provide systematic procedures for monitoring, auditing and minimising environmental impacts associated with construction works and operational activities.

1.1.2 Hong Kong environmental regulations and the Hong Kong Planning Standards and Guidelines have served as environmental standards and guidelines in the preparation of this Manual. In addition, the EM&A Manual has been prepared in accordance with the requirements stipulated in Annex 21 of the Technical Memorandum on the EIA Process (EIAO-TM).

1.1.3 This Manual contains the following information:

- responsibilities of the Contractor, the Engineer or Engineer's Representative (ER), Environmental Team (ET), and the Independent Environmental Checker (IEC) with respect to the environmental monitoring and audit requirements during the course of the project;
- project organisation for the project;
- the basis for, and description of the broad approach underlying the EM&A programme;
- requirements with respect to the construction programme schedule and the necessary environmental monitoring and audit programme to track the varying environmental impact;
- details of the methodologies to be adopted, including all field laboratories and analytical procedures, and details on quality assurance and quality control programme;
- the rationale on which the environmental monitoring data will be evaluated and interpreted;
- definition of Action and Limit levels;
- establishment of Event and Action plans;
- requirements for reviewing pollution sources and working procedures required in the event of non-compliance with the environmental criteria and complaints;
- requirements for presentation of environmental monitoring and audit data and appropriate reporting procedures; and
- requirements for review of EIA predictions and the effectiveness of the mitigation measures / environmental management systems and the EM&A programme.

1.1.4 For the purpose of this manual, the ET leader, who shall be responsible for and in charge of the ET, shall refer to the person delegated the role of executing the EM&A requirements.

1.2 Project Description

1.2.1 The Project "Central-Wan Chai Bypass" (CWB) involves the construction of a trunk road, mostly in tunnel, that connects the existing Rumsey Street Flyover in Central to the existing Island Eastern Corridor to the east of the existing Causeway Bay Typhoon Shelter (CBTS), to form an east-west strategic vehicular route along the north shore of Hong Kong Island as shown in **Figure 1.1**.

1.2.2 The scope of the Project comprises:

- (i) a dual three-lane trunk road, approximately 4.5 km in length, with tunnel approximately 3.7 km in length defined from the connection with the existing Rumsey Street Flyover in

Central, through to a connection with the existing Island Eastern Corridor to the east of the existing Causeway Bay Typhoon Shelter;

- (ii) the Central Interchange near the Rumsey Street Flyover to provide road connections, to the Central Area;
- (iii) tunnel control buildings and ventilation buildings,
- (iv) slip roads to connect the CWB to the local road system in the Wan Chai North and Causeway Bay area;
- (v) associated road lighting, road signing, traffic control and surveillance system; and
- (vi) other associated works.

1.2.3 This EM&A Manual covers the monitoring and audit programme requirements for the construction of the CWB under the Environmental Permit (EP) No. EP-364/2009/A, issued on 4 August 2010.

1.2.4 This EM&A Manual does not cover the tunnel structure works of the CWB within the Central Reclamation Phase III (CRIII) area in the Central waterfront area. The tunnel structure works of the CWB within the CRIII area are separately covered by the EP No. EP-122/2002 and the further environmental permit No. FEP-01/122/2003, and their subsequently amended versions.

1.2.5 This EM&A Manual does not cover the permanent and temporary reclamation and associated dredging works related to the CWB construction either. These works are separately covered by the EP No. EP-356/2009.

1.2.6 This EM&A Manual also does not cover the Road P2 and other roads which are classified as primary / district distributor roads in Wan Chai waterfront near Hong Kong Convention and Exhibition Centre (referred to as "DP2" in the WDII&CWB EIA Report (Register No. AEIAR-125/2008)). These works are separately covered by EP No. EP-376/2009.

1.2.7 The following approved EIA Reports covered the works under EP No. EP-364/2009/A :

- Central-Wan Chai Bypass and Island Eastern Corridor Link Environmental Impact Assessment Report (July 2001) (Register No. AEIAR-041/2001) (the CWB&IECL EIA Report); and
- Wan Chai Development Phase II and Central-Wan Chai Bypass Environmental Impact Assessment Report (December 2007) (Register No. AEIAR-125/2008) (the WDII & CWB EIA Report).

1.3 Environmental Monitoring and Audit Requirements

1.3.1 The following sub-sections summarise the EM&A requirements recommended in the EIA Reports for the Project.

Air Quality Impact

Construction Phase

1.3.2 The construction work will inevitably lead to dust (Total Suspended Particulates, TSP) emissions, mainly from excavation, truck haulage and material handling. It is predicted that the dust generated will exceed the hourly and daily criteria of $500 \mu\text{g m}^{-3}$ and $260 \mu\text{g m}^{-3}$, respectively, at ASRs from Wan Chai to Causeway Bay.

- 1.3.3 Mitigation measures, including vehicle speed limit and a watering programme within the site, have been proposed and presented in the EIA Reports. With implementation of the proposed dust suppression measures, good site practices and comprehensive dust monitoring and audit, the TSP levels at all ASRs will comply with the dust criteria. Dust monitoring requirements are recommended in Section 2 of this EM&A Manual to ensure the efficacy of the control measures.

Operational Phase

- 1.3.4 As presented in Volume 1, Section 3.7 of the WDII & CWB EIA Report, the predicted air quality due to traffic emission in the study area complies with the AQO. No mitigation measures or environmental monitoring are considered necessary during the operational phase of the Project. Regarding the odour issue, this Project will not create any new odour source during operational phase.

Noise Impact

Construction Phase

- 1.3.5 Construction noise impacts from this Project, in addition to the concurrent construction tasks of other projects such as CRIII, are predicted at the NSRs identified in the EIA. Appropriate mitigation measures, including movable noise barriers and reducing the percentage of on-time operation of the powered mechanical equipment, are required in order to alleviate the impacts to meet the EIAO-TM criteria. Noise monitoring during construction phase will have to be carried out to ensure that such mitigation measures have been implemented properly. Details are provided in Section 3 of this EM&A Manual.
- 1.3.6 A real-time on-site monitoring system of the noise level around the works sites at North Point and Tin Hau areas shall be carried out during the construction phase. The methodology is also presented in Section 3 of this EM&A Manual.

Operational Phase

- 1.3.7 Traffic noise monitoring shall be carried out at all designated traffic noise monitoring stations during the operation phase. The details are provided in Section 3.6 and 3.7 of this EM&A Manual.
- 1.3.8 Noise monitoring shall be carried out during the testing and commissioning stages of ventilation buildings to verify the maximum sound power levels as assumed in the noise assessments contained in the CWB&IECL EIA Report and the WDII&CWB EIA Report. The details are provided in Section 3.8 of this EM&A Manual.

Water Quality Impact

Construction Phase

- 1.3.9 The potential water quality impacts arising from the proposed construction works for the CWB have been assessed and are presented in the EIA Reports. As the water quality impacts arising from the reclamation for the construction of the CWB have been covered under the Environmental Permit No. EP-356/2009, the primary concern with regard to water quality for the construction of the CWB will be the control of runoff during construction. The EIA concluded that the identified water quality impacts could be controlled and reduced to within acceptable levels through effective mitigation. Monitoring of marine water quality during the construction phase is therefore not considered necessary.
- 1.3.10 Environmental audit specifications should be developed for all phases of the works, including procedures to ensure compliance with mitigation measures, environmental quality performance limits, and procedures for reviewing results and auditing compliance with specified performance limits.

Operational Phase

- 1.3.11 A surface water drainage system shall be provided to collect road runoff. The following operation stage mitigation measures are recommended to ensure road runoff would comply with the Technical Memorandum, Standards for Effluents Discharged into Drainage and Sewerage Systems, Inland and Coastal Waters under the Water Pollution Control Ordinance (WPCO):
- The drainage from tunnel sections should be directed through petrol interceptors to remove oil and grease before being discharged to the nearby foul water manholes.
 - Petrol interceptors should be regularly cleaned and maintained in good working condition.
 - Road drainage should be provided with adequately designed silt trap so as to minimise discharge of silt runoff.
 - Oily contents of the petrol interceptors should be collected and transferred to an appropriate disposal facility.
- 1.3.12 Sewage arising from ancillary facilities of CWB (for example, car park, control room, ventilation and administration buildings and tunnel portals) shall be connected to public sewerage system. Sufficient capacity in public sewerage shall be made available to the proposed facilities to avoid overflow.
- 1.3.13 The design of the operational stage mitigation measures should take into account the guidelines published in ProPECC PN 5/93 "Drainage Plans Subject to Comment by the EPD." All discharges into drainage or sewerage systems during the operation phase shall be licensed by the EPD under the WPCO.

Waste Management

- 1.3.14 Waste management will be the contractor's responsibility to ensure that all wastes produced during the construction of the Project are handled, stored and disposed of in accordance with EPD's good waste management practices, and regulations and requirements. The mitigation measures recommended include special procedures in handling contaminated sediment during disposal and transportation, good site management and reuse and recycling of construction and demolition material, should form the basis of the site Waste Management Plan to be developed by the Contractor at the construction stage. These measures include special handling procedures in dredged marine sediment transportation and disposal, good site practices and waste reduction measures, reuse and recycling of construction and demolition materials.
- 1.3.15 It is recommended that the waste arisings generated during the construction activities should be audited periodically to determine if wastes are being managed in accordance with approved procedures and the site Waste Management Plan. The audits should look at all aspects of waste management including waste generation, storage, recycling, transport and disposal. An appropriate audit programme would be to undertake a first audit near the commencement of the construction works, and then to audit quarterly thereafter. Details are presented in Section 5 of this EM&A Manual.

Land Contamination

Construction Phase

- 1.3.16 As there will be no adverse land contamination impact arising from the construction of the CWB, construction phase land contamination monitoring and audit is considered not necessary and will not be covered in this EM&A Manual.

Operational Phase

- 1.3.17 As adverse land contamination impact is not anticipated from the operation of the Project, operational land contamination monitoring and audit is considered not necessary and will not be covered in this EM&A Manual.

Marine Ecology

- 1.3.18 The construction and operation of the CWB will not give rise to impacts to marine ecology. Hence monitoring and audit for marine ecology is considered not necessary and will not be covered in this EM&A Manual.

Landscape and Visual Impact

Construction Phase

- 1.3.19 Construction activities would give rise to landscape and visual impacts varying from slight to substantial significance.
- 1.3.20 The landscape and visual mitigation measures for the construction phase are described in Volume 1, Section 10 of the WDII & CWB EIA Report. The measures are on-site management measures to be undertaken by the contractor. Monitoring of the contractor to ensure that the measures are carried out properly should be undertaken by resident site staff.

Operational Phase

- 1.3.21 The operation of the CWB would give rise to landscape and visual impacts of varying from moderate negative to moderate beneficial. Overall, it is considered that the residual landscape and visual impacts of the proposed CWB are considered **acceptable with mitigation measures** during operation up to 10 years and **beneficial with mitigation** in the long run after 20 to 30 years.
- 1.3.22 The proposed landscape and visual mitigation measures are described in Volume 1, Section 10 of the EIA Report. The measures are design measures to be incorporated in the detailed planning and design of the reclamation, infrastructure and open space works.

1.4 Project Organisation

- 1.4.1 The construction of the Project will involve several construction Contracts and hence multiple contractors may be employed at the work site. In view of this, an ET should be employed (or an Environmental Project Office (ENPO) be established) by the Project Proponent to maintain impartially. The proposed project organisation and lines of communication with respect to environmental protection works are shown in Figure 1.2.

Figure 1.2 Project Organisation

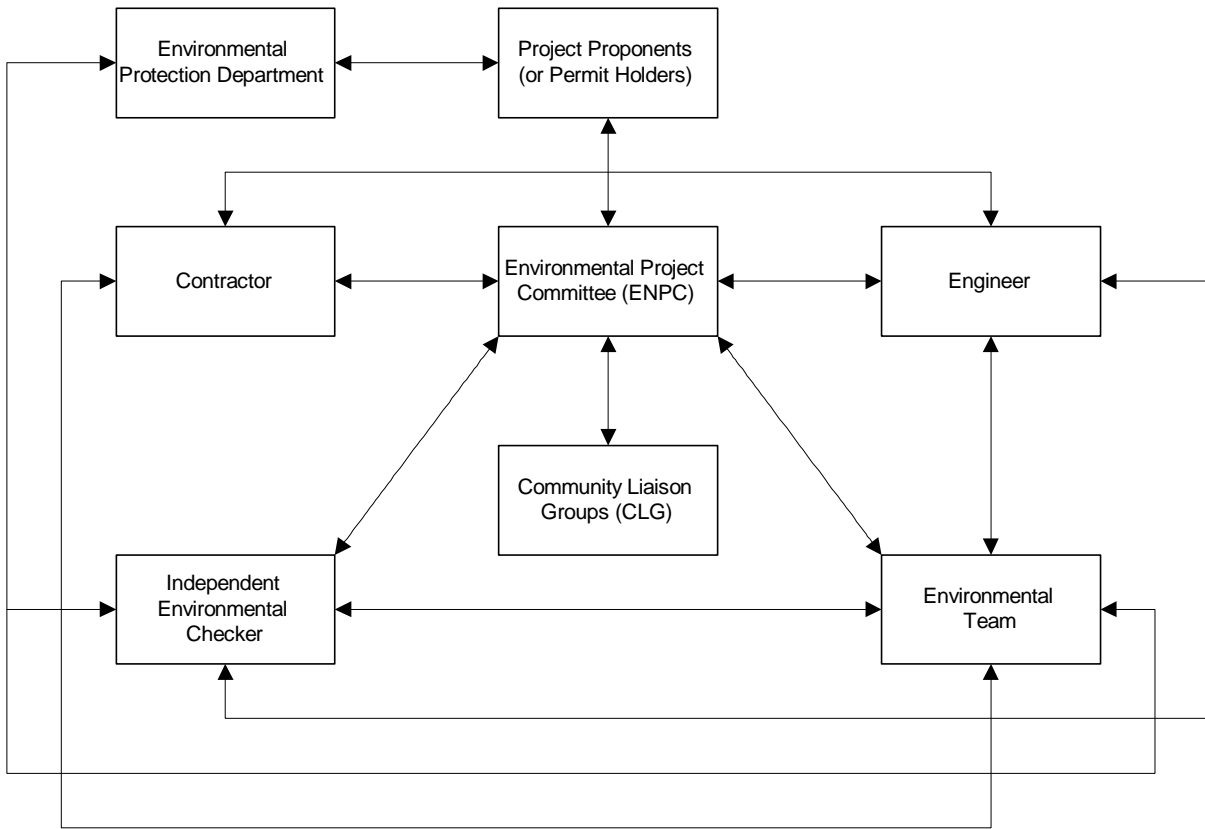

The Contractor

1.4.2 The Contractor shall report to the Engineer. The duties and responsibilities of the Contractor are:

- provide assistance to ET in carrying out monitoring;
- submit proposals on mitigation measures in case of exceedances of Action and Limit levels in accordance with the Event and Action Plans;
- implement measures to reduce impact where Action and Limit levels are exceeded; and
- adhere to the procedures for carrying out complaint investigation in accordance with Section 9.3 of this EM&A Manual.

Environmental Team

1.4.3 The ET Leader and the ET shall be employed to conduct the EM&A programme and ensure the Contractor's compliance with the project's environmental performance requirements during construction. The ET Leader shall be an independent party from the Contractor and have relevant professional qualifications, or have sufficient relevant EM&A experience subject to approval of the Environmental Protection Department (EPD). The ET shall be led and managed by the ET leader. The ET leader shall possess at least 7 years experience in EM&A. The ET team shall include a landscape auditor to audit the mitigation measures implemented by the Contractor on a regular basis to ensure compliance with the intended aims of the measures. The duties and responsibilities of the ET are:

- monitor various environmental parameters as required in the EM&A Manual;
- analyse the environmental monitoring and audit data and review the success of EM&A programme to cost-effectively confirm the adequacy of mitigation measures implemented and the validity of the EIA predictions and to identify any adverse environmental impacts arising;
- carry out site inspection to investigate and audit the Contractors' site practice, equipment and work methodologies with respect to pollution control and environmental mitigation, and effect proactive action to pre-empt problems;
- audit and prepare audit reports on the environmental monitoring data and site environmental conditions;
- report on the environmental monitoring and audit results to the IEC, Contractor, the ER and EPD or its delegated representative;
- recommend suitable mitigation measures to the Contractor in the case of exceedance of Action and Limit levels in accordance with the Event and Action Plans; and
- adhere to the procedures for carrying out complaint investigation in accordance with Section 9.3 of this EM&A Manual.

Engineer or Engineer's Representative

1.4.4 The Engineer is responsible for overseeing the construction works and for ensuring that the works undertaken by the Contractor in accordance with the specification and contractual requirements. The duties and responsibilities of the Engineer with respect to EM&A may include:

- supervise the Contractor's activities and ensure that the requirements in the EM&A Manual are fully complied with;
- inform the Contractor when action is required to reduce impacts in accordance with the Event and Action Plans; and
- adhere to the procedures for carrying out complaint investigation in accordance with Section 9.3 of this EM&A Manual.

Independent Environmental Checker (IEC)

1.4.5 The IEC shall advise the Engineer's Representative on environmental issues related to the project. The IEC shall possess at least 7 years experience in EM&A. The duties and responsibilities of the IEC are:

- review the EM&A works performed by the ET (at not less than monthly intervals);
- audit the monitoring activities and results (at not less than monthly intervals);
- report the audit results to the ER and EPD in parallel;

- review the EM&A reports (monthly and quarterly summary reports) submitted by the ET;
 - review the proposal on mitigation measures submitted by the Contractor in accordance with the Event and Action Plans; and
 - adhere to the procedures for carrying out complaint investigation in accordance with Section 9.3 of this EM&A Manual.
- 1.4.6 Sufficient and suitably qualified professional and technical staff shall be employed by the respective parties to ensure full compliance with their duties and responsibilities, as required under the EM&A programme for the duration of the Project.

Environmental Project Committee (ENPC)

- 1.4.7 To oversee and facilitate effective control of the cumulative environmental impacts arising from potential multiple contracts for the construction of the entire Wan Chai Development Phase II (WDII) and Central-Wan Chai Bypass (CWB) (hereafter referred to as the whole Project), the Permit Holder shall set up an Environmental Project Committee (ENPC) before the commencement of construction of the earliest components of the whole Project. Regular members of the ENPC will include:
- (a) the ET Leader;
 - (b) the IEC; and
 - (c) the permit holders of any environmental permit(s) and further environmental permit(s) for the whole Project.

The Community Liaison Group formed shall also work under the ENPC set-up to facilitate any necessary liaison works to address potential cumulative environmental impact issues arising from the whole Project. The ENPC shall make recommendation and update on how to enhance the monitoring and audit of the environmental performance of the whole Project on top of requirements as set out in Conditions 3.1 to 4.3 of the Environmental Permit No. EP-364/2009/A or corresponding requirements set out under subsequent Environmental Permits issued for the whole Project.

In order to enhance the monitoring and audit environmental performance of the project, ENPC will be required to set up regular meeting on monthly basis in association with environmental site inspection for the entire Wan Chai Development Phase II (WDII) and Central-Wan Chai Bypass (CWB) to undertake the latest cumulative environmental impacts. The frequency of the meeting will be reviewed subject to the environmental performance of the whole Project and ad-hoc meeting will be required if necessary.

The proposed terms of reference and details for the ENPC is presented in **Appendix E**.

Community Liaison Group (CLG)

Community Liaison Group will comprise representatives from the relevant concerned and affected parties, including owners' corporation, management offices, local committee and schools of affected areas, including the North Point and Tin Hau areas, to facilitate communication, enquires and complaint handling on all environmental issues, including the follow up on the implementation of remedial mitigation measures. Regular meeting on monthly basis will be setup for the Community Liaison Group to update the latest cumulative environmental impacts due to the project. The frequency of the meeting will be reviewed subject to the environmental performance of the whole Project and ad-hoc meeting will be required if necessary.

- 1.4.8 The Permit Holder shall set up the CLG before the commencement of construction of the relevant component(s) of the WDII and CWB Project. The Permit Holder shall notify the Director the actual date of setting up the CLG, the membership, the terms of reference and the contact details. A designated complaint hotline shall also be set up for the Project to address such

concerns and complaints in an efficient manner. The detailed arrangements of the CLG shall be reported to the ENPC and its activities be reflected as update under Condition 2.5(a) of the Environmental Permit No. EP-364/2009/A.

The proposed terms of reference and details for the CLG is presented in **Appendix E**.

1.5 Latest Project Information

- 1.5.1 The CWB construction works covered by EP-364/2009/A have commenced in early 2010. The latest construction works programme covered by EP-364/2009/A is included in **Appendix G**. Updated works programmes of individual works contracts will be provided once available.

CONTENTS

2	AIR QUALITY	2-1
2.1	Introduction	2-1
2.2	Air Quality Parameters	2-1
2.3	Monitoring Equipment	2-1
2.4	Laboratory Measurement / Analysis	2-2
2.5	Monitoring Locations	2-3
2.6	Baseline Monitoring.....	2-4
2.7	Impact Monitoring of Construction Air Quality Impact	2-5
2.8	Environmental Quality Performance Limits	2-5
2.9	Event and Action Plan for Construction Air Quality	2-5
2.10	Construction Dust Mitigation Measures	2-7
2.11	Tunnel Emission	2-7
2.12	Operation Phase Air Quality Monitoring	2-8

LIST OF TABLES

Table 2.1	Locations of Dust Monitoring Locations
Table 2.2	Division of Dust Monitoring Stations for contracts with construction work commenced/to be commenced in 2010
Table 2.3	Action / Limit Levels for Air Quality
Table 2.4	Event / Action Plan for Air Quality
Table 2.5	Tunnel Air Quality Guidelines

LIST OF FIGURES

Figure 2.2	Locations of Air Quality Monitoring Stations
------------	--

LIST OF APPENDICES

Appendix A	Implementation Schedule of Recommended Mitigation Measures
Appendix B	Data Record Sheet

2 AIR QUALITY

2.1 Introduction

- 2.1.1 In this section, the requirements, methodology, equipment, monitoring locations, criteria and protocols for the monitoring and audit of air quality impacts during the construction phase of the CWB are presented. As construction dust is the prime concern, levels of Total Suspended Particulates (TSP) shall be monitored to evaluate the dust impact during the construction phase.
- 2.1.2 There will be no exceedance of AQOs at the sensitive receivers and hence air quality monitoring is considered not necessary during the operation phase of the Project. Nevertheless, the operator for the proposed CWB Tunnel, HyD, will conduct air quality monitoring for the operation performance of the EVB ventilation shaft. Details of the air quality monitoring should be formulated in the detailed design stage subject to agreement between EPD and HyD.

2.2 Air Quality Parameters

Construction Phase

- 2.2.1 Monitoring of the TSP levels shall be carried out by the ET to ensure that deteriorating air quality could be readily detected and timely action taken to rectify the situation.
- 2.2.2 One-hour and 24-hour TSP levels should be measured to indicate the impacts of construction dust on air quality. The 24-hour TSP levels shall be measured by following the standard high volume sampling method as set out in the Title 40 of the Code of Federal Regulations, Chapter 1 (Part 50), Appendix B. Upon approval of the ER, 1-hour TSP levels can be measured by direct reading methods which are capable of producing comparable results as that measured by the high volume sampling method, to indicate short event impacts.
- 2.2.3 All relevant data including temperature, pressure, weather conditions, elapsed-time meter reading for the start and stop of the sampler, identification and weight of the filter paper, and any other local atmospheric factors affecting or affected by site conditions etc. shall be recorded down in detail. A sample data sheet is shown in **Appendix B1**.

Operation Phase

- 2.2.4 During the operation phase, the operator for the proposed CWB tunnel, HyD, will conduct air quality monitoring of NO₂ and RSP concentrations in a regular interval to indicate the operation performance of the EVB ventilation shaft. The methodology, equipment, monitoring locations, and criteria for the monitoring should be formulated in the detailed design stage subject to the agreement between EPD and HyD.

2.3 Monitoring Equipment

- 2.3.1 High volume samplers (HVSs) in compliance with the following specifications shall be used for carrying out the 1-hour and 24-hour TSP monitoring:
- 0.6 - 1.7 m³ per minute adjustable flow range;
 - equipped with a timing / control device with +/- 5 minutes accuracy for 24 hours operation;
 - installed with elapsed-time meter with +/- 2 minutes accuracy for 24 hours operation;
 - capable of providing a minimum exposed area of 406 cm²;
 - flow control accuracy: +/- 2.5% deviation over 24-hour sampling period;
 - equipped with a shelter to protect the filter and sampler;
 - incorporated with an electronic mass flow rate controller or other equivalent devices;
 - equipped with a flow recorder for continuous monitoring;
 - provided with a peaked roof inlet;
 - incorporated with a manometer;

- k) able to hold and seal the filter paper to the sampler housing at horizontal position;
- l) easily changable the filter; and
- m) capable of operating continuously for 24-hour period.

- 2.3.2 The ET is responsible for provision of the monitoring equipment. They shall ensure that sufficient number of HVS's with appropriate calibration kit are available for carrying out the baseline monitoring, regular impact monitoring and ad hoc monitoring. The HVSs shall be equipped with an electronic mass flow controller and be calibrated against a traceable standard at regular intervals. All the equipment, calibration kit, filter papers, etc. shall be clearly labelled.
- 2.3.3 Initial calibration of dust monitoring equipment shall be conducted upon installation and thereafter at bi-monthly intervals. The transfer standard shall be traceable to the internationally recognised primary standard and be calibrated annually. The concerned parties such as ER shall properly document the calibration data for future reference. All the data should be converted into standard temperature and pressure condition.
- 2.3.4 The flow-rate of the sampler before and after the sampling exercise with the filter in position shall be verified to be constant and be recorded in the data sheet as mentioned in **Appendix B1**.
- 2.3.5 If the ET proposes to use a direct reading dust meter to measure 1-hour TSP levels, he shall submit sufficient information to the ER to prove that the instrument is capable of achieving a comparable result to the HVS. The instrument should also be calibrated regularly, and the 1-hour sampling shall be determined periodically by the HVS to check the validity and accuracy of the results measured by direct reading method.
- 2.3.6 Wind data monitoring equipment shall also be provided and set up for logging wind speed and wind direction near the dust monitoring locations. The equipment installation location shall be proposed by the ET and agreed with the ER. For installation and operation of wind data monitoring equipment, the following points shall be observed:
- a) The wind sensors should be installed 10 m above ground so that they are clear of obstructions or turbulence caused by buildings.
 - b) The wind data should be captured by a data logger. The data shall be downloaded for analysis at least once a month.
 - c) The wind data monitoring equipment shall be re-calibrated at least once every six months.
 - d) Wind direction should be divided into 16 sectors of 22.5 degrees each.
- 2.3.7 In exceptional situations, the ET may propose alternative methods to obtain representative wind data upon approval from the ER and agreement from the EPD.

2.4 Laboratory Measurement / Analysis

- 2.4.1 A clean laboratory with constant temperature and humidity control, and equipped with necessary measuring and conditioning instruments to handle the dust samples collected, shall be available for sample analysis, and equipment calibration and maintenance. The laboratory should be HOKLAS accredited.
- 2.4.2 If a site laboratory is set up or a non-HOKLAS accredited laboratory is hired for carrying out the laboratory analysis, the laboratory equipment shall be approved by the ER and the measurement procedures shall be witnessed by the ER. Any measurement performed by the laboratory shall be demonstrated to the satisfaction of the IE(C) who shall regularly audit to the measurement performed by the laboratory to ensure the accuracy of measurement results. The ET Leader shall provide the ER with one copy of the Title 40 of the Code of Federal Regulations, Chapter 1 (Part 50), Appendix B for his reference.
- 2.4.3 Filter paper of size 8" x 10" shall be labelled before sampling. It shall be a clean filter paper with no pinholes, and shall be conditioned in a humidity-controlled chamber for over 24-hours and be pre-weighed before use for sampling.

2.4.4 After sampling, the filter paper loaded with dust shall be kept in a clean and tightly sealed plastic bag. The filter paper shall then be returned to the laboratory for reconditioning in the humidity-controlled chamber followed by accurate weighing by an electronic balance with readout down to 0.1 mg. The balance shall be regularly calibrated against a traceable standard.

2.4.5 All the collected samples shall be kept in a good condition for 6 months before disposal.

2.5 Monitoring Locations

2.5.1 Based on the findings of the EIA report, 6 representative locations which would be the worst affected locations in different area are designated for construction dust monitoring. As per the consent obtained from appropriate sensitive receiver for provision of location for monitoring, the latest status revealed a total of 7 dust monitoring stations for construction phase will be required and are presented in **Table 2.1** and shown in **Figure 2.2** proposed after seeking approval from ER and agreement from the IEC. The status and locations of dust sensitive receivers may change after issuing this manual. If such cases exist, the ET Leader shall propose updated monitoring locations and seek approval from ER and agreement from the IEC on the proposal.

Table 2.1 Locations of Dust Monitoring Locations

Identification No.	Monitoring Location	Level (in terms of no. of floor)
MA1e	Central – International Finance Centre Mall (Eastern End of Podium)	3/F
MA1w	Central – International Finance Centre Mall (Western End of Podium)	3/F
CMA1b	North Point – Oil Street Community Liaison Centre	G/F
CMA2a	Causeway Bay – Causeway Bay Community Centre	4/F (lower roof-top)
CMA3a	Causeway Bay – CWB site Office at Wanchai Waterfront Promenade	3/F
CMA4a	Wanchai – Society for the Prevention of Cruelty to Animals	6/F (roof-top)
CMA5a	Wanchai – Children Playgrounds opposite to Pedestrian Plaza	G/F

2.5.2 When alternative monitoring locations are proposed, the monitoring should, as far as practicable:

- a) be at the site boundary or such locations close to the major dust emission source;
- b) be close to the sensitive receptors; and
- c) take into account the prevailing meteorological conditions.

2.5.3 The ET shall agree with the ER on the position of the HVS for the installation of the monitoring equipment. When positioning the samplers, the following points shall be noted:

- a) a horizontal platform with appropriate support to secure the samplers against gusty wind should be provided;
- b) no two samplers should be placed less than 2 meters apart;
- c) the distance between the sampler and an obstacle, such as buildings, must be at least twice the height that the obstacle protrudes above the sampler;
- d) a minimum of 2 meters of separation from walls, parapets and penthouses is required for rooftop samplers;
- e) a minimum of 2 meters separation from any supporting structure, measured horizontally is required;
- f) no furnace or incinerator flue is nearby;
- g) airflow around the sampler is unrestricted;
- h) the sampler is more than 20 meters from the dripline;

- i) any wire fence and gate, to protect the sampler, should not cause any obstruction during monitoring;
- j) permission must be obtained to set up the samplers and to obtain access to the monitoring stations; and
- k) a secured supply of electricity is needed to operate the samplers.

Commencement of Dust Monitoring Programme in Stages

- 2.5.4 As per the condition 2.5(c) under EP-364/2009/A, environmental monitoring and the execution of Event & Action Plan (EAP) are considered based on taken into account of the latest works schedules, division of responsibilities among different contracts in the Project, and latest project information. Division of work areas under different contracts will be managed under separate FEPs applied by individual contractors.
- 2.5.5 In terms of division of work areas, the proposed division of dust monitoring stations and its commencement in stages are summarized in **Table 2.2**.

Table 2.2 Division of Dust Monitoring Stations for contracts with construction work commenced/to be commenced in 2010

Contract No.	Associated DP(s)	Relevant Dust Monitoring Stations ¹	Commencement of monitoring w.r.t construction commencement
04/HY/2006 (bus terminus), HY/2009/18	DP1	MA1e, MA1w	Sep 2010
HY/2009/17 (piling work)	DP1	CMA2a	Oct 2010
HY/2009/19	DP1	CMA1b, CMA2a	DP1 construction work ¹
HY/2009/15	DP1	CMA3a	DP1 construction work on reclaimed land area ¹
HK/2009/02	DP1	CMA4a	DP1 construction work on reclaimed land area ¹
HK/2009/01	DP1	CMA5a	DP1 construction work on reclaimed land area ¹

Note 1: Subject to actual commencement date to be confirmed.

2.6 Baseline Monitoring

Construction Phase

- 2.6.1 Baseline monitoring shall be carried out at all of the designated monitoring locations for at least 14 consecutive days prior to the commissioning of the construction works to obtain daily 24-hour TSP samples. The selected baseline monitoring stations should reflect baseline conditions at the impact stations. One-hour sampling should also be done at least 3 times per day while the highest dust impact is expected.
- 2.6.2 During the baseline monitoring, there should not be any construction or dust generation activities in the vicinity of the monitoring stations. Before commencing baseline monitoring the ET shall inform the ER of the baseline monitoring programme such that the ER can conduct on-site audit to ensure accuracy of the baseline monitoring results.
- 2.6.3 In case the baseline monitoring cannot be carried out at the designated monitoring locations during the baseline monitoring period, the ET Leader shall carry out the monitoring at alternative locations

which can effectively represent the baseline conditions at the impact monitoring locations. The alternative baseline monitoring locations shall be approved by the ER and IEC and agreed with EPD.

- 2.6.4 In exceptional cases, when insufficient baseline monitoring data or questionable results are obtained, the ET shall liaise with the ER to agree on an appropriate set of data to be used as a baseline reference and submit to ER for approval.
- 2.6.5 Ambient conditions may vary seasonally and shall be reviewed once every three months. When the ambient conditions have changed, a repeat of the baseline monitoring is required to be carried out for obtaining the updated baseline levels. The monitoring should be at times when the Contractor's activities are not generating dust, at least in the proximity of the monitoring stations. Should change in ambient conditions be determined, the baseline levels and, in turn, the air quality criteria, should be revised. The revised baseline levels and air quality criteria shall be agreed with EPD.

2.7 Impact Monitoring of Construction Air Quality Impact

- 2.7.1 The ET shall carry out impact monitoring during the course of the Works. For regular impact monitoring, the sampling frequency of at least once in every six-days, shall be strictly observed at all the monitoring stations for 24-hour TSP monitoring. For 1-hour TSP monitoring, the sampling frequency of at least three times in every six-days should be undertaken when the highest dust impact occurs. Before commencing baseline monitoring, the ET shall inform the ER of the impact monitoring programme.
- 2.7.2 The specific time to start and stop the 24-hour TSP monitoring shall be clearly defined for each location and be strictly followed by the operator.
- 2.7.3 In case of non-compliance with the air quality criteria, more frequent monitoring, as specified in the Action Plan in the following section, shall be conducted within 24 hours after the result is obtained. This additional monitoring shall be continued until the excessive dust emission or the deterioration in air quality is rectified.

2.8 Environmental Quality Performance Limits

- 2.8.1 The baseline monitoring results form the basis for determining the air quality criteria for the impact monitoring. The ET shall compare the impact monitoring results with air quality criteria set up for 24-hour TSP and 1-hour TSP. **Table 2.3** shows the air quality criteria, namely Action and Limit levels to be used.

Table 2.3 Action / Limit Levels for Air Quality

Parameters	Action	Limit
24-hour TSP Level in mg m^{-3}	For baseline level $\leq 200 \text{ mg m}^{-3}$, Action level = (baseline level * 1.3 + Limit level)/2; For baseline level $> 200 \text{ mg m}^{-3}$ Action level = Limit level	260
1-hour TSP Level in mg m^{-3}	For baseline level $\leq 384 \text{ mg m}^{-3}$, Action level = (baseline level * 1.3 + Limit level)/2; For baseline level $> 384 \text{ mg m}^{-3}$, Action level = Limit level	500

2.9 Event and Action Plan for Construction Air Quality

- 2.9.1 Should non-compliance of the air quality criteria occur, actions in accordance with the Action Plan in **Table 2.4** shall be carried out.

Table 2.4 Event / Action Plan for Air Quality

EVENT	ACTION			
	ET	IEC	ER	CONTRACTOR
ACTION LEVEL				
1.Exceedance for one sample	<ol style="list-style-type: none"> Identify source, investigate the causes of exceedance and propose remedial measures; Inform IEC and ER; Repeat measurement to confirm finding; Increase monitoring frequency to daily. <p>(The above actions should be taken within 2 working days after the exceedance is identified)</p>	<ol style="list-style-type: none"> Check monitoring data submitted by ET; Check Contractor's working method. <p>(The above actions should be taken within 2 working days after the exceedance is identified)</p>	<ol style="list-style-type: none"> Notify Contractor. <p>(The above actions should be taken within 2 working days after the exceedance is identified)</p>	<ol style="list-style-type: none"> Rectify any unacceptable practice; Amend working methods if appropriate. <p>(The above actions should be taken within 2 working days after the exceedance is identified)</p>
2.Exceedance for two or more consecutive samples	<ol style="list-style-type: none"> Identify source; Inform IEC and ER; Advise the ER on the effectiveness of the proposed remedial measures; Repeat measurements to confirm findings; Increase monitoring frequency to daily; Discuss with IEC and Contractor on remedial actions required; If exceedance continues, arrange meeting with IEC and ER; If exceedance stops, cease additional monitoring. <p>(The above actions should be taken within 2 working days after the exceedance is identified)</p>	<ol style="list-style-type: none"> Check monitoring data submitted by ET; Check Contractor's working method; Discuss with ET and Contractor on possible remedial measures; Advise the ET on the effectiveness of the proposed remedial measures; Supervise Implementation of remedial measures. <p>(The above actions should be taken within 2 working days after the exceedance is identified)</p>	<ol style="list-style-type: none"> Confirm receipt of notification of failure in writing; Notify Contractor; Ensure remedial measures properly implemented. <p>(The above actions should be taken within 2 working days after the exceedance is identified)</p>	<ol style="list-style-type: none"> Submit proposals for remedial to ER within 3 working days of notification; Implement the agreed proposals; Amend proposal if appropriate. <p>(The above actions should be taken within 2 working days after the exceedance is identified)</p>
LIMIT LEVEL				
1.Exceedance for one sample	<ol style="list-style-type: none"> Identify source, investigate the causes of exceedance and propose remedial measures; Inform ER, Contractor and EPD; Repeat measurement to confirm finding; Increase monitoring frequency to daily; Assess effectiveness of Contractor's remedial actions and keep IEC, EPD and ER informed of the results. <p>(The above actions should be taken within 2 working days after the exceedance is identified)</p>	<ol style="list-style-type: none"> Check monitoring data submitted by ET; Check Contractor's working method; Discuss with ET and Contractor on possible remedial measures; Advise the ER on the effectiveness of the proposed remedial measures; Supervise implementation of remedial measures. <p>(The above actions should be taken within 2 working days after the exceedance is identified)</p>	<ol style="list-style-type: none"> Confirm receipt of notification of failure in writing; Notify Contractor; Ensure remedial measures properly implemented. <p>(The above actions should be taken within 2 working days after the exceedance is identified)</p>	<ol style="list-style-type: none"> Take immediate action to avoid further exceedance; Submit proposals for remedial actions to IEC within 3 working days of notification; Implement the agreed proposals; Amend proposal if appropriate. <p>(The above actions should be taken within 2 working days after the exceedance is identified)</p>
2.Exceedance for two or more consecutive samples	<ol style="list-style-type: none"> Notify IEC, ER, Contractor and EPD; Identify source; Repeat measurement to confirm findings; Increase monitoring frequency to daily; Carry out analysis of Contractor's working procedures to determine possible mitigation to be implemented; Arrange meeting with IEC and ER to discuss the remedial actions to be taken; Assess effectiveness of Contractor's remedial actions and keep IEC, EPD and ER informed of the results; If exceedance stops, cease additional monitoring. <p>(The above actions should be taken within 2 working days after the exceedance is identified)</p>	<ol style="list-style-type: none"> Discuss amongst ER, ET, and Contractor on the potential remedial actions; Review Contractor's remedial actions whenever necessary to assure their effectiveness and advise the ER accordingly; Supervise the implementation of remedial measures. 	<ol style="list-style-type: none"> Confirm receipt of notification of failure in writing; Notify Contractor; In consolidation with the IEC, agree with the Contractor on the remedial measures to be implemented; Ensure remedial measures properly implemented; If exceedance continues, consider what portion of the work is responsible and instruct the Contractor to stop that portion of work until the exceedance is abated. <p>(The above actions should be taken within 2 working days after the exceedance is identified)</p>	<ol style="list-style-type: none"> Take immediate action to avoid further exceedance; Submit proposals for remedial actions to IEC within 3 working days of notification; Implement the agreed proposals; Resubmit proposals if problem still not under control; Stop the relevant portion of works as determined by the ER until the exceedance is abated. <p>(The above actions should be taken within 2 working days after the exceedance is identified)</p>

2.10 Construction Dust Mitigation Measures

2.10.1 The following mitigation measures are recommended:

- strictly limit the truck speed on site to below 10 km per hour and use water spraying to keep the haul roads in wet condition;
- Four times a day watering of the work site with active operations when the weather and the work site are dry;
- watering during excavation and material handling;
- provision of vehicle wheel and body washing facilities at the exit points of the site, combined with cleaning of public roads where necessary; and
- tarpaulin covering of all dusty vehicle loads transported to, from and between site locations.

2.10.2 If the above measures are not sufficient to restore the air quality to acceptable levels upon the advice of ET Leader, the Contractor shall liaise with the ET Leader on some other mitigation measures, propose to ER for approval, and implement the mitigation measures.

2.10.3 The implementation schedule for the mitigation measures is presented in Appendix A.

2.11 Tunnel Emission

2.11.1 The tunnel air quality monitoring requirements for the control of air pollution in vehicle tunnels are presented in the following:

Air Quality Parameters and Standards

2.11.2 Table 2.5 shows the air quality guidelines that should be attained and maintained inside a vehicle tunnel. In addition, the visibility in the tunnel should be controlled to a level equivalent to an extinction coefficient of 0.005 per metre or less during any 5-minute interval.

Table 2.5 Tunnel Air Quality Guidelines

Air Pollutants	Averaging Time	Maximum Concentration	
		Micrograms Per Cubic Metre ($\mu\text{g}/\text{m}^3$)	Parts Per Million (ppm)
CO	5 minutes	115,000	100
NO ₂	5 minutes	1,800	1
SO ₂	5 minutes	1,000	0.4

Monitoring Requirement

2.11.3 Concentrations of carbon monoxide, nitrogen dioxide and visibility should be continuously monitored inside the underpass (tunnel section of the CWB). The tunnel management should install and operate at least one analyser for each pollutant at each kilometre section of the tunnel.

2.11.4 Air quality impacts associated with road traffic are caused mostly by NO₂ and RSP with reference to Wan Chai Development Phase II and Central-Wan Chai Bypass – EIA Report (Volume 1). In addition, under the Air Pollution Control (Motor Vehicle Fuel) (Amendment) Regulation 2010, any motor vehicle diesel and unleaded petrol must contain not more than 10.0 mg/kg of sulphur, as

determined in accordance with EN ISO 20884:2004. In view of the low emission rates relative to the statutory limit, SO₂ would comply the tunnel air quality limit.

- 2.11.5 The monitoring of nitrogen dioxide may be replaced by nitric oxide through the application of the following equation or any correlation relationship between these two parameters demonstrated to have a regression coefficient of not less than 0.85:

$$\text{Nitrogen dioxide concentration } (\mu\text{g}/\text{m}^3) = 320 + 0.1056 \times \text{Nitric oxide concentration } (\mu\text{g}/\text{m}^3)$$

- 2.11.6 Direct measurement of NO₂ should be conducted when more suitable NO₂ sensors become available in market. In case NO₂ sensors are installed, they would have to be replaced over reasonable period of time when more suitable NO₂ sensors become available in market.
- 2.11.7 Tunnel management should forward the results of monitoring once per month on a floppy disk in such a format agreeable to the EPD.
- 2.11.8 All monitoring instruments should be checked for zero and span once a week and calibrated and certified by an independent environmental laboratory in accordance with the criteria.
- 2.11.9 The analysers should activate an audible alarm at the main control room of the tunnel whenever the measured carbon monoxide and nitrogen dioxide concentrations exceed 60,000 $\mu\text{g}/\text{m}^3$ and 1,000 $\mu\text{g}/\text{m}^3$, respectively. Prompt action including restriction of the traffic flow and other means acceptable to the EPD should be taken by the tunnel operator based on a suitable action level agreed with EPD or other regulatory authority.

2.12 Operation Phase Air Quality Monitoring

- 2.12.1 During the operation phase, the operator for the proposed CWB tunnel, HyD, will conduct air quality monitoring of NO₂ and RSP concentrations in a regular interval to indicate the operation performance of the EVB ventilation shaft. The methodology, equipment, monitoring locations, and criteria for the monitoring should be formulated in the detailed design stage subject to the agreement between EPD and HyD.

CONTENTS

3 NOISE 3-1

3.1 Introduction 3-1

3.2 Noise Parameters..... 3-1

3.3 Monitoring Equipment 3-1

3.4 Baseline Monitoring..... 3-2

3.5 Impact Monitoring of Construction Noise Impact 3-2

3.6 Event And Action Plan For Construction Noise..... 3-4

3.7 Noise Mitigation Measures 3-6

3.8 Operational Phase Noise Monitoring 3-7

LIST OF TABLES

Table 3.1a Noise Monitoring Stations during Construction Phase

Table 3.1b Real-time Noise Monitoring Stations during Construction Phase

Table 3.2 Division of Noise Monitoring Stations for contracts with construction work commenced/to be commenced in 2010

Table 3.3 Action and Limit Levels for Construction Noise

Table 3.4 Event / Action Plan for Construction Noise

Table 3.5 Noise Monitoring Stations during Operational Phase

LIST OF FIGURES

Figure 3.1 Locations of Noise Monitoring Stations

LIST OF APPENDICES

Appendix A Implementation Schedule of Recommended Mitigation Measures

Appendix B Data Record Sheet

3 NOISE

3.1 Introduction

- 3.1.1 Representative noise sensitive receivers (NSRs) along the proposed alignment have been identified and assessed in the EIA Report. It is predicted that some NSRs will be subjected to daytime and restricted hour construction noise. The monitoring programme shall be carried out by the ET to ensure that the noise level of construction works complies with the criteria of the Noise Control Ordinance (NCO) and noise criteria laid down by the contract.

3.2 Noise Parameters

Construction Phase

- 3.2.1 The construction noise level shall be measured in terms of the A-weighted equivalent continuous sound pressure level (L_{eq}). L_{eq} (30 minutes) shall be used as the monitoring parameter for the time period between 0700 and 1900 hours on normal weekdays. For all other time periods, L_{eq} (5 minutes) shall be employed for comparison with the Noise Control Ordinance (NCO) criteria.
- 3.2.2 As supplementary information for data auditing, statistical results such as L_{10} and L_{90} shall also be obtained for reference. A sample data record sheet is shown in Appendix B2 for reference.

Operation Phase

- 3.2.3 The traffic noise level shall be measured twice within the first year of the road opening. Measurement shall be made in terms of A-weighted L_{10} over three half-hour periods during the peak traffic hour. Other metrics like L_{eq} may be added as seen fit. A sample data record sheet is shown in **Appendix B** for reference.
- 3.2.4 Fixed plant noise monitoring shall be carried out for the ventilation buildings. Measurements shall be made in accordance with the procedures outlined in the 'Technical Memorandum for the Assessment of Noise from Places other than Domestic Premises, Public Places and Construction Sites' (IND-TM).

3.3 Monitoring Equipment

- 3.3.1 As referred in the Technical Memorandum (TM) issued under the NCO, sound level meters in compliance with the International Electrotechnical Commission Publications 651: 1979 (Type 1) and 804: 1985 (Type 1) specifications shall be used for carrying out the noise monitoring. Immediately prior to and following each noise measurement the accuracy of the sound level meter shall be checked using an acoustic calibrator generating a known sound pressure level at a known frequency. Measurements may be accepted as valid only if the calibration level from before and after the noise measurement agree to within 1.0 dB.
- 3.3.2 Noise measurements should not be made in the presence of fog, rain, and wind with a steady speed exceeding 5 m s^{-1} or wind with gusts exceeding 10 ms^{-1} . The wind speed shall be checked with a portable wind speed meter capable of measuring the wind speed in meter per second.
- 3.3.3 The ET is responsible for provision of the monitoring equipment. He shall ensure that sufficient noise measuring equipment and associated instrumentation are available for carrying out the baseline monitoring, regular impact monitoring and ad hoc monitoring. All the equipment and associated instrumentation shall be clearly labelled.

3.4 Baseline Monitoring

- 3.4.1 The ET shall carry out baseline noise monitoring prior to the commencement of the construction works. The baseline monitoring shall be carried out daily for a period of at least two weeks. A schedule of baseline monitoring shall be submitted to the ER for approval before the monitoring starts.
- 3.4.2 There shall not be any construction activities in the vicinity of the monitoring stations during the baseline monitoring.
- 3.4.3 In exceptional cases, when insufficient baseline monitoring data or questionable results are obtained, the ET shall liaise with the IEC and EPD to agree on an appropriate set of data to be used as a baseline reference and submit to the ER for approval.

3.5 Impact Monitoring of Construction Noise Impact

- 3.5.1 Noise monitoring shall be carried out at all the designated monitoring stations. The monitoring frequency shall depend on the scale of the construction activities. The following is an initial guide on the regular monitoring frequency for each station on a per week basis when noise generating activities are underway:

(a) one set of measurements between 0700 and 1900 hours on normal weekdays.

- 3.5.2 A real-time on-site monitoring system of the noise level around the works sites at North Point and Tin Hau areas should be carried out during the construction phase. The detailed monitoring system is presented as follows and **Appendix F**:

(a) Instrumentation

- Sound level meter in compliance with the International Electrotechnical Commission Publications 651: 1979 (Type 1) and 804: 1985 (Type 1) specifications shall be used for carrying out the noise monitoring.
- Capable of giving continuous readout of the noise level readings including equivalent continuous sound pressure level (L_{eq}) and 10th and 90th percentile of sound level pressure level (L_{10} & L_{90}).

(b) Methodology

- A weatherproof enclosure shall be installed to protect the sound level meter and the communications hardware from sunlight and rain. This enclosure shall be mounted against the handrail and bolted on the wall if necessary.
- Noise monitoring shall be automatically conducted for 24 hours a day. Data will be instantaneously transmitted to a central office through the use of communication hardware and software.
- Power supply shall be provided for the real-time noise monitoring system.

(c) Calibration of equipment

- The sound level meter shall be checked using an acoustic calibrator generating a known sound pressure level at a known frequency before deployment to the site and during each site visit. Measurements may be accepted as valid only if the calibration level from before and after the noise measurement agree to within 1.0 dB.

(d) Data Reporting

- An electronic system shall be set-up to track, manage and data reporting, as well as automatic compliance assessment.
- The electronic system shall also report the instantaneous monitoring results on a dedicated website.
- The current practice on the noise screening is via adjustment by ET and IEC. This will be the additional measures to avoid erroneous noise data.

- 3.5.3 The locations of construction noise monitoring stations are summarised in **Table 3.1a** and **Table 3.1b** and shown in **Figure 3.1**.

Table 3.1a Noise Monitoring Stations during Construction Phase

Identification No.	Noise Monitoring Location	Level (in terms of no. of floor)
M1a	Harbour Road Sports Centre	3/F
M2b	Noon Gun Area	G/F
M3a	Tung Lo Wan Fire Station	3/F (roof-top)
M4b	Victoria Centre	2/F
M5b	City Garden	G/F
M6	Hong Kong Baptist Church Henrietta Secondary School	6/F (rooftop)
M7e	International Finance Centre Mall (Eastern End of Podium)	3/F
M7w	International Finance Centre Mall (Western End of Podium)	3/F

Table 3.1b Real-time Noise Monitoring Stations during Construction Phase

Real-time Noise Monitoring Station	Noise Monitoring Location (District)	Level (in terms of no. of floor)	Commencement of Monitoring
RTN1	FEHD Whitfield Depot (Tin Hau)	1/F (podium)	IECL Pilling works
RTN1a	Tung Lo Wan Fireboat Station (Tin Hau)	3/F (roof-top)	IECL Pilling works and Demolition
RTN1b	Causeway Bay Community Centre (Tin Hau)	5/F (roof-top)	IECL Bridge Demolition
RTN2	Oil Street Community Liaison Centre (North Point)	1/F (roof-top)	IECL Bridge Demolition
RTN3	Hong Kong Baptist Church Henrietta Secondary School (North Point)	6/F (rooftop)	IECL Bridge Demolition

- 3.5.4 In case of non-compliance with the construction noise criteria, more frequent monitoring, as specified in the Event and Action Plan in **Table 3.3**, shall be carried out. This additional monitoring shall be continued until the recorded noise levels are rectified or proved to be irrelevant to the construction activities.
- 3.5.5 A schedule on the compliance monitoring shall be submitted to the ER and IEC for approval before the monitoring starts.
- 3.5.6 Owing to the nature of the works under the project, construction activities will shift from one location to another from time to time, and the status and locations of the noise sensitive receivers may change after issuing this manual. If such cases exist, the ET Leader shall propose updated monitoring locations and seek approval from ER and agreement from the IEC. The monitoring locations should be chosen based on the following criteria:
- at locations close to the major site activities which are likely to have noise impacts;
 - close to the most affected existing noise sensitive receivers; and

- for monitoring locations located in the vicinity of the sensitive receivers, care should be taken to cause minimal disturbance to the occupants during monitoring.
- 3.5.7 The monitoring station shall normally be at a point 1 m from the exterior of the sensitive receiver building facade and be at a position 1.2 m above the ground. If there is problem with access to the normal monitoring position, an alternative position may be chosen, and a correction to the measurements shall be made. For reference, a correction of +3 dB(A) shall be made to the free field measurements. The ET shall agree with the IEC on the monitoring position and the corrections adopted. Once the positions for the monitoring stations are chosen, the baseline monitoring and the impact monitoring shall be carried out at the same positions.
- Commencement of Noise Monitoring Programme in Stages
- 3.5.8 As per the condition 2.5(c) under EP-364/2009/A, environmental monitoring and the execution of Event & Action Plan (EAP) are considered based on taken into account of the latest works schedules, division of responsibilities among different contracts in the Project, and latest project information. Division of work areas under different contracts will be managed under separate FEPs applied by individual contractors.
- 3.5.9 In terms of division of work areas, the proposed division of noise monitoring stations and its commencement in stages are summarized in **Table 3.2**.

Table 3.2 Division of Noise Monitoring Stations for contracts with construction work commenced/to be commenced in 2010

Contract No.	Associated DP(s)	Relevant Dust Monitoring Stations ¹	Commencement of monitoring w.r.t construction commencement
04/HY/2006 (bus terminus), HY/2009/18	DP1	M7e, M7w	Sep 2010
HY/2009/17 (piling work)	DP1	M4b, RTN1, RTN2	Oct 2010
HY/2009/15	DP1	M2b	Oct 2010
HY/2009/19	DP1	M3a, M4b, M5b, M6	Nov 2010
HK/2009/01, HK/2009/02	DP1	M1a	Pier demolition work & PTI reconstruction ¹

Note 1: Subject to actual commencement date to be confirmed.

3.6 Event And Action Plan For Construction Noise

- 3.6.1 The Action and Limit levels for construction noise are defined in **Table 3.3**. Should non-compliance of the criteria occur, action in accordance with the Action Plan in **Table 3.4**, shall be carried out.

Table 3.3 Action and Limit Levels for Construction Noise

Time Period	Action Level	Limit Level
0700 - 1900 hours on normal weekdays	When one documented complaint is received	75 dB(A) *

Note : If works are to be carried out during restricted hours, the conditions stipulated in the construction noise permit issued by the Noise Control Authority have to be followed.

* Reduce to 70 dB(A) for schools and 65 dB(A) during school examination periods.

Table 3.4 Event / Action Plan for Construction Noise

EVENT	ACTION			
	ET	IEC	ER	CONTRACTOR
Action Level	<ol style="list-style-type: none"> 1. Identify source, investigate the causes of exceedance and propose remedial measures; 2. Notify IEC and Contractor; 3. Report the results of investigation to the ER and Contractor; 4. Discuss with the Contractor and formulate remedial measures; 5. Increase monitoring frequency to check mitigation effectiveness. 	<ol style="list-style-type: none"> 1. Review the analysed results submitted by the ET; 2. Review the proposed remedial measures by the Contractor and advise the ER accordingly; 3. Supervise the implementation of remedial measures. 	<ol style="list-style-type: none"> 1. Confirm receipt of notification of failure in writing; 2. Notify Contractor; 3. Require Contractor to propose remedial measures for the analysed noise problem; 4. Ensure remedial measures are properly implemented. 	<ol style="list-style-type: none"> 1. Submit noise mitigation proposals to IEC; 2. Implement noise mitigation proposals.
Limit Level	<ol style="list-style-type: none"> 1. Identify source; 2. Inform IEC, ER, EPD and Contractor; 3. Repeat measurements to confirm findings; 4. Increase monitoring frequency; 5. Carry out analysis of Contractor's working procedures to determine possible mitigation to be implemented; 6. Inform IEC, ER and EPD the causes and actions taken for the exceedances; 7. Assess effectiveness of Contractor's remedial actions and keep IEC, EPD and ER informed of the results; 8. If exceedance stops, cease additional monitoring. 	<ol style="list-style-type: none"> 1. Discuss amongst ER, ET, and Contractor on the potential remedial actions; 2. Review Contractor's remedial actions whenever necessary to assure their effectiveness and advise the ER accordingly; 3. Supervise the implementation of remedial measures. 	<ol style="list-style-type: none"> 1. Confirm receipt of notification of failure in writing; 2. Notify Contractor; 3. Require Contractor to propose remedial measures for the analysed noise problem; 4. Ensure remedial measures properly implemented; 5. If exceedance continues, consider what portion of the work is responsible and instruct the Contractor to stop that portion of work until the exceedance is abated. 	<ol style="list-style-type: none"> 1. Take immediate action to avoid further exceedance; 2. Submit proposals for remedial to IEC within 3 working days of notification; 3. Implement the agreed proposals; 4. Resubmit proposals if problem still not under control; 5. Stop the relevant portion of works as determined by the ER until the exceedance is abated.

3.7 Noise Mitigation Measures

3.7.1 The EIA Report has recommended the following construction noise control and mitigation measures during construction.

Construction Phase

3.7.2 The Contractor shall be responsible for the design and implementation of the following measures. The key measures are:

- use of quieter and silenced equipment for road construction and site development;
- use of movable noise barriers for particular plant;
- reduction of on-time operation of the powered mechanical equipment during the construction of Bridge M, demolition of the existing Island Eastern Corridor and CWB tunnel near the Hong Kong Convention and Exhibition Centre.

3.7.3 Temporary noise barriers (5m in height) with cantilevered upper portion (3.5m in length) are proposed in NPR2W, NPR1, NPR2E work sites along the diaphragm wall of the tunnel section and retaining walls of the tunnel approach ramp for alleviation of construction noise during construction of diaphragm walls and substructures of the tunnel approach ramp. Temporary noise barriers with height up to the soffit of the bridge deck area are proposed along the existing IEC structure for alleviation of construction noise during the demolition and construction of substructures for the IEC and construction of adjacent tunnel approach ramp structures. A 10 dB(A) noise reduction can be achieved by eliminating the line of sight from the receivers along the construction areas. The barrier material shall have a surface mass of not less than 14 kg/m² on skid footing with 25mm thick internal sound absorptive lining to achieve the maximum screening effect.

3.7.4 Additionally, apart from the temporary noise barrier, temporary noise barriers to be mounted on the existing piers of IEC are also proposed for the demolition works of existing piers and crossheads of the marine section of the existing IEC.

3.7.5 PMEs grouping for IECL substructure construction works and slip Road 8 at-grade road works, either Group 1 or 2 can be operated at any one time under the construction schedule, are also proposed in order to further minimize noise impact to the receivers.

3.7.6 In addition, there are also many good site practices recommended as follows:

- only well-maintained plant should be operated on-site and plant should be serviced regularly during the construction program;
- silencers or mufflers on construction equipment should be utilised and should be properly maintained during the construction program;
- mobile plant, if any, should be sited as far away from NSRs as possible;
- machinery and plant (such as trucks) that may be in intermittent use should be shut down between work periods or should be throttled down to a minimum;
- plant known to emit noise strongly in one direction should, where possible, be orientated so that the noise is directed away from nearby NSRs; and
- material stockpiles and other structures should be effectively utilised, where practicable, in screening noise from on-site construction activities.

- 3.7.7 If the above measures are not sufficient to restore the construction noise quality to an acceptable level upon the advice of ET Leader, the contractor shall liaise with the ET Leader to identify further mitigation measures. They shall be proposed to ER for approval, and the contractor shall then implement these additional mitigation measures.
- 3.7.8 Appropriate mitigation measures shall be adopted for the use of pneumatic breakers, if required to demolish the existing Island Eastern Corridor, to be confined to the period from 0900 to 1700 hours on weekdays (Monday to Friday), and the pneumatic breakers shall not be used any time on Saturdays, Sundays and general holidays, and during examination hours of the schools affected by the works site, including:
- (i) Hong Kong Baptist Church Henrietta Secondary School; and
 - (ii) Po Leung Kuk Yu Lee Mo Fan Memorial School;

3.8 Operational Phase Noise Monitoring

- 3.8.1 As the noise sensitive receivers close to the proposed road will be exposed to traffic noise during the operational phase, a noise monitoring programme shall be developed to include noise measurements at noise sensitive receivers during the peak traffic hour. The programme shall be carried out by the Environmental Team (ET) to ensure that the traffic noise levels are comparable to those predicted in the EIA under the full provision of the mitigation measures recommended. Operational noise monitoring will also be required during commissioning stage of ventilation buildings to ensure that the compliance with the noise limits specified in the EIA Report has been achieved. HyD will be responsible for the operational phase monitoring.

Traffic Noise

Noise Parameters

- 3.8.2 The traffic noise level shall be measured twice within the first year of the road opening. Measurement shall be made in terms of the A-weighted L_{10} over three half-hour periods during the peak traffic hour. Other metrics like L_{eq} may be added as seen fit. A sample data record sheet is shown in the Appendix D. More details could be referred to Section 3.8.3.

Monitoring Equipment

- 3.8.3 Sound level meters to be used shall be in compliance with the International Electrotechnical Commission Publications 651: 1979 (Type 1) and 804: 1985 (Type 1) specifications for carrying out the noise monitoring. Immediately prior to and following each noise measurement the accuracy of the sound level meter shall be checked using an acoustic calibrator generating a known sound pressure level at a known frequency. Measurements may be accepted as valid only if the calibration level from before and after the noise measurement agree to within 1.0 dB(A).
- 3.8.4 Noise measurement should be made in accordance with standard acoustical principles and practices in relation to weather conditions.
- 3.8.5 The ET Leader is responsible for the provision and maintenance of the monitoring equipment. He shall ensure that sufficient noise measuring equipment and associated instrumentation are available for carrying out the baseline monitoring, regular impact monitoring and ad hoc monitoring. All the equipment and associated instrumentation shall be clearly labelled.

Monitoring Locations

- 3.8.6 The operational noise monitoring locations are summarised in **Table 3.5**. The status and locations of noise sensitive receivers may change after issuing the Environmental Monitoring and Audit Manual. In such cases, the ET Leader shall propose updated monitoring locations and seek approval from the Engineer's Representative, and agreement from the IEC and EPD to the proposal. The monitoring locations are based on the following criteria for selection:
- (a) They should be at NSRs in the vicinity of recommended direct technical remedies;
 - (b) One high floor and one medium floor monitoring points should be chosen at each location as far as possible; and
 - (c) Selected monitoring locations should enable monitoring to be done twice within one year after implementation of the mitigation measures during operation of the proposed road.

Table 3.5 Noise Monitoring Stations during Operational Phase

Noise Monitoring Station	Noise Monitoring Location
M1	Block 1, Victoria Centre
M2	Block 11, City Garden

- 3.8.7 When alternative monitoring locations are proposed, the monitoring locations shall be chosen based on the following criteria:
- (a) they shall be similarly exposed to potential noise impacts;
 - (b) they shall be close to the noise sensitive receivers; and
 - (c) they shall be located so as to cause minimal disturbance to the occupants.
- 3.8.8 The operational noise monitoring shall be carried out a distance of 1 m from the openable window and 1.2 m above the floor level of the noise sensitive receivers identified. The ET Leader shall agree with the IEC on any necessary corrections adopted.

Baseline Monitoring

- 3.8.9 No baseline operational noise monitoring is required.

Impact Monitoring

- 3.8.10 Traffic noise monitoring shall be carried out at all the designated traffic noise monitoring stations. The following is an initial guide on the traffic noise monitoring requirements during the operational phase :
- (a) one set of measurements at the morning traffic peak hour on normal weekdays;
 - (b) one set of measurements at the evening traffic peak hour on normal weekdays;
 - (c) a concurrent census of traffic flow and percentage heavy vehicle shall be obtained for far-side and near-side of the road and the existing road network in the vicinity of each measuring point;
 - (d) average vehicle speed estimated for far-side and near-side of the road and the existing road network in the vicinity of each measuring point; and
 - (e) the two sets of monitoring data should be obtained within the first year of operation.
- 3.8.11 Measured noise levels should be compared with predicted noise levels by applying appropriate conversion corrections to allow for the traffic conditions at the time of measurement. Appendix D shows a sample data record sheet for operational noise monitoring.
- 3.8.12 In case discrepancies are observed, explanation should be given to justify the discrepancies.

Noise Mitigation Measures

3.8.13 In the EIA Report, a series of mitigation measures have been considered for the proposed road to reduce the noise impacts at the NSRs. The mitigation measures for existing NSRs include:

- about 235m length of noise semi-enclosure covering the westbound slip road from the IEC
- about 230m length of noise semi-enclosure covering the main carriageways (eastbound and westbound) of the CWB and IEC
- about 135m length of 5.5m high cantilevered noise barrier with 4.5m cantilever inclined at 45° on the eastbound slip road to the IEC (amended under EP – 364/2009/A)
- about 95m length of 5.5m high cantilevered noise barrier with 1m cantilever inclined at 45° on the eastbound slip road to the IEC
- about 350m length of 3.5m high vertical noise barrier on the eastbound slip road to the IEC
- low noise road surfacing for the trunk road (except tunnel section and beneath the landscaped deck at the eastern portal area) with speed limit of 70 km/hour

3.8.14 The mitigation measures for future/planned NSRs include:

- about 265m length of noise semi-enclosure covering the westbound slip road from the Island Eastern Corridor shall be installed before the occupation of planned noise sensitive receivers (NSRs) in the Comprehensive Development Areas (CDA) near Oil Street, North Point
- The openable windows of the temple, if any, should be orientated so as to avoid direct line of sight to the existing Victoria Park Road as far as practicable.

Fixed Plant Noise

3.8.15 It is recommended that noise monitoring is carried out for the ventilation buildings on three occasions: Day one of commissioning, Day 60 of operation, and when the ventilation buildings are operating at maximum capacity.

3.8.16 Noise measurements shall be made in accordance with the procedures outlined in the 'Technical Memorandum for the Assessment of Noise from Places other than Domestic Premises, Public Places and Construction Sites' (IND-TM).

3.8.17 The monitoring location shall be outside the ventilation buildings at a distance of 1 m from the centre of the louvre. Two types of measurement shall be carried out:

- Broadband measurement of $L_{eq (30 \text{ minutes})}$ dB(A). Shorter measurement period may be used if it can be demonstrated that the noise level is constant.
- Frequency analysis between 31.5 Hz and 16 kHz measured at 1/3 octave intervals. If the noise emanating from the louvre is found to be tonal (as defined in IND-TM) then an appropriate tonal correction should be applied to the measured noise level to achieve the corrected noise level (CNL). The CNL shall be compared with the noise specifications.

- 3.8.18 This monitoring and audit program on noise during the testing and commissioning stages of ventilation buildings is to verify the maximum sound power levels as assumed in the noise assessments contained in the approved CWB&IECL EIA Report (Register No. AEIAR-041/2001) and the WDII&CWB EIA Report (Register No. AEIAR-125/2008). In case the maximum sound power levels under this audit programme exceed those assumed in the EIA Reports, the Permit Holder shall investigate with a view to recommend remedial actions; shall deposit the investigation report with the Director, and implement the recommended remedial actions where appropriate.

Noise Mitigation Measures

- 3.8.19 Silencers shall be provided at all exhaust fans installed in East Ventilation Building, Central Ventilation Building and Western Ventilation Building.

CONTENTS

4 WATER QUALITY4-1

4.1 Introduction..... 4-1

4.2 Water Quality Impacts Mitigation Measures during Construction Phase..... 4-1

4.3 Water Quality Impacts Mitigation Measures during Operational Phase 4-2

4 WATER QUALITY

4.1 Introduction

- 4.1.1 The potential water quality impacts arising from the proposed construction works for the CWB have been assessed and are presented in the EIA Report. As the water quality impacts arising from the reclamation for the construction of the CWB have been covered under the DP3 under the Environmental Permit No. EP-356/2009, the primary concern with regard to water quality under DP1 will be the control of runoff during construction. The EIA concluded that the identified water quality impacts could be controlled and reduced to within acceptable levels through effective mitigation. Monitoring of marine water quality during the construction phase is therefore not considered necessary.
- 4.1.2 During the site inspections, the ET Leader shall pay special attention to the issues relating to water quality, and check whether the Contractor has followed the relevant contract specifications and the procedures specified under the laws of Hong Kong. Stringent control and audit will be necessary to ensure that effective water pollution control measures are being implemented. Site inspection should include regular checking of the proposed measures and records of maintenance services to ensure their proper functioning.
- 4.1.3 The following is a summary of the recommended water quality mitigation measures. The implementation schedule for water pollution control is given in Appendix A.

4.2 Water Quality Impacts Mitigation Measures during Construction Phase

Site Runoff

- 4.2.1 All site construction runoff should be controlled and treated to prevent high levels of SS entering nearby water bodies. The site practices outlined in ProPECC PN 1/94 "Construction Site Drainage" should be followed as far as practicable in order to minimise surface runoff and the chance of erosion, and also to retain and reduce any SS prior to discharge. In particular:
- temporary ditches should be provided to facilitate runoff discharge into the appropriate watercourses, via sedimentation traps / silt retention ponds;
 - permanent drainage channels should also incorporate sediment basins or traps, and baffles to enhance deposition rates;
 - sand / silt removal facilities such as sand traps, silt traps and sediment basins should be provided to remove sand / silt particles from run-off. These facilities should be regularly cleaned and maintained by the Contractor. The design of silt removal facilities shall be based on the guidelines in Appendix A1 of ProPECC PN 1/94;
 - collection of spent bentonite / other grouts in a separate slurry collection system for either cleaning and reuse or disposal to landfill should be implemented;
 - maintenance and plant areas should be bunded and constructed on a hard standing with the provision of sediment traps and petrol interceptors;
 - all drainage facilities must be adequate for the controlled release of storm flows;
 - careful programming of the works to minimise surface excavation works during the rainy season;
 - exposed soil areas should be minimised to reduce the potential for increased siltation and contamination of runoff;

- all fuel tanks and storage areas shall be contained (bunded) such that spills are not allowed to gain access to water bodies;
- open drainage channels and culverts adjacent to the site shall be kept safe and free from any debris and excavated materials arising from the works;
- open stockpiles of construction materials (for examples, aggregates, sand and fill material) of more than 50 m³ should be covered with tarpaulin or similar fabric during rainstorms; and
- as and when necessary, installation and regular maintenance of silt screen at seawater intakes in the vicinity of the site.

4.2.2 Precautions to be taken at any time of year when rainstorms are likely, actions to be taken when a rainstorm is imminent or forecast, and actions to be taken during or after rainstorms are summarised in Appendix A2 of ProPECC PN 1/94.

Debris and Litter

4.2.3 In order to maintain water quality of an aesthetically acceptable condition, contractors should be required, under conditions of contract, to ensure that site management is optimised and that disposal of any solid materials, litter or wastes to marine waters does not occur. Entrapment boom should be installed to avoid loss of floating refuse from construction site. Regular scavenging shall be provided to collect both the trapped and escaped refuse.

Oils and Solvents

4.2.4 All fuel tanks and storage areas shall be provided with locks and be sited on sealed areas, within bunds of a capacity equal to 110% of the storage capacity. All maintenance and plant areas together with chemical and chemical waste storage areas shall be provided with cover to avoid ingress of rainwater. Waste chemical should be handled, treated and disposed of in accordance with the legislative requirements.

Sewage Effluent

4.2.5 Temporary sanitary facilities, such as portable chemical toilets, shall be provided on-site by a licensed contractor. A licensed contractor shall be responsible for appropriate disposal and maintenance of these facilities. There will be no new sewage outfall during construction and operation of the CWB & IECL.

4.3 Water Quality Impacts Mitigation Measures during Operational Phase

4.3.1 A surface water drainage system shall be provided to collect road runoff. The following operation stage mitigation measures are recommended to ensure road runoff would comply with the Technical Memorandum, Standards for Effluents Discharged into Drainage and Sewerage Systems, Inland and Coastal Waters under the Water Pollution Control Ordinance (WPCO):

- The drainage from tunnel sections should be directed through petrol interceptors to remove oil and grease before being discharged to the nearby foul water manholes.
- Petrol interceptors should be regularly cleaned and maintained in good working condition.
- Road drainage should be provided with adequately designed silt trap so as to minimise discharge of silt runoff.
- Oily contents of the petrol interceptors should be collected and transferred to an appropriate disposal facility.

-
- 4.3.2 Sewage arising from ancillary facilities of CWB (for example, car park, control room, ventilation and administration buildings and tunnel portals) shall be connected to public sewerage system. Sufficient capacity in public sewerage shall be made available to the proposed facilities to avoid overflow.
- 4.3.3 The design of the operational stage mitigation measures should take into account the guidelines published in ProPECC PN 5/93 "Drainage Plans Subject to Comment by the EPD." All discharges into drainage or sewerage systems during the operation phase shall be licensed by the EPD under the WPCO.

CONTENTS

5 WASTE MANAGEMENT 5-1
5.1 Introduction 5-1
5.2 Waste Control and Mitigation Measures..... 5-1

5 WASTE MANAGEMENT

5.1 Introduction

5.1.1 Waste management will be the contractor's responsibility to ensure that all wastes generated during construction of the CWB are handled, stored and disposed of in accordance with good waste management practices and EPD's regulations and requirements.

5.1.2 Waste materials generated during construction activities, such as construction and demolition (C&D) materials, chemical wastes and general refuse from the workforce, are recommended to be audited periodically to determine if wastes are being managed in accordance with approved procedures and the site Waste Management Plan. The audits should look at all aspects of waste management including waste generation, storage, recycling, transport and disposal. An appropriate audit programme would be to undertake a first audit at the commencement of the construction works, and then to audit quarterly thereafter. The Contractor will be responsible for the implementation of any mitigation measures to minimise waste arisings or to redress problems arising from the waste materials.

5.2 Waste Control and Mitigation Measures

5.2.1 Mitigation measures for waste management of the DP1 are summarised below. The Implementation Schedule of the recommended mitigation measures for DP1 is presented in **Appendix A**. In order to ensure that the mitigation measures are properly implemented by the Contractor, regular site inspections by the ET shall be carried out at least once per week. Details of the audit requirements are set out in Section 9 of this EM&A Manual.

Good Site Practices

5.2.2 Adverse impacts related to waste management are not expected to arise, provided that good site practices are strictly followed. Recommendations for good site practices during the construction activities include:

- Nomination of an approved person, such as a site manager, to be responsible for good site practices, arrangements for collection and effective disposal to an appropriate facility, of all wastes generated at the site.
- Training of site personnel in proper waste management and chemical waste handling procedures.
- Provision of sufficient waste disposal points and regular collection for disposal.
- Appropriate measures to minimise windblown litter and dust during transportation of waste by either covering trucks or by transporting wastes in enclosed containers.
- Regular cleaning and maintenance programme for drainage systems, sumps and oil interceptors.
- A recording system for the amount of wastes generated, recycled and disposed of (including the disposal sites).

Waste Reduction Measures

5.2.3 Good management and control can prevent the generation of a significant amount of waste. Waste reduction is best achieved at the planning and design stage, as well as by ensuring the implementation of good site practices. Recommendations to achieve waste reduction include:

- Sort C&D waste from demolition of the existing waterfront structures to recover recyclable portions such as metals.

- Segregation and storage of different types of waste in different containers, skips or stockpiles to enhance reuse or recycling of materials and their proper disposal.
- Encourage collection of aluminium cans, PET bottles and paper by providing separate labelled bins to enable these wastes to be segregated from other general refuse generated by the work force.
- Any unused chemicals or those with remaining functional capacity shall be recycled.
- Use of reusable non-timber formwork, such as in casting the tunnel box sections, to reduce the amount of C&D material.
- Proper storage and site practices to minimise the potential for damage or contamination of construction materials.
- Plan and stock construction materials carefully to minimise amount of waste generated and avoid unnecessary generation of waste.

5.2.4 In addition to the above measures, specific mitigation measures are recommended below for the identified waste arisings to minimise environmental impacts during handling, transportation and disposal of these wastes.

General Refuse

5.2.5 General refuse should be stored in enclosed bins or compaction units separate from C&D material. A licensed waste collector should be employed by the contractor to remove general refuse from the site, separately from C&D material. Preferably an enclosed and covered area should be provided to reduce the occurrence of 'wind-blown' light material.

Chemical Wastes

5.2.6 After use, chemical wastes (for example, cleaning fluids, solvents, lubrication oil and fuel) should be handled according to the *Code of Practice on the Packaging, Labelling and Storage of Chemical Wastes*. Spent chemicals should be collected by a licensed collector for disposal at the CWTF or other licensed facility, in accordance with the Waste Disposal (Chemical Waste) (General) Regulation.

Construction and Demolition Material

5.2.7 The C&D material should be sorted on-site into inert C&D material (that is, public fill) and C&D waste. Considering that a large quantity of C&D material will be generated from the demolition works and excavation for the tunnel construction and in order to minimise the impact resulting from collection and transportation of material for off-site disposal, it is recommended that the inert C&D material should be re-used on-site in the reclamation works as far as practicable. All the suitable (inert) material should be broken down to 250 mm in size for reuse as public fill and surcharge in the WDII reclamation. C&D waste, such as wood, glass, plastic, steel and other metals should be reused or recycled and, as a last resort, disposed of to landfill. It is recommended that a suitable area be designated to facilitate the sorting process and a temporary stockpiling area will be required for the separated materials.

5.2.8 In order to monitor the disposal of public fill and C&D waste at public fill reception facilities and landfills, respectively, and to control fly tipping, a trip-ticket system should be included as one of the contractual requirements and implemented by an Environmental Team undertaking the Environmental Monitoring and Audit work. An Independent Environmental Checker should be responsible for auditing the results of the system.

5.2.9 Bentonite slurries used in diaphragm wall and bore-pile construction should be reconditioned and reused wherever practicable. The disposal of residual used bentonite slurry should follow the good practice guidelines stated in ProPECC PN 1/94 "Construction Site Drainage" and listed as follows:

-
- If the disposal of a certain residual quantity cannot be avoided, the used slurry may be disposed of at the marine spoil grounds subject to obtaining a marine dumping licence from EPD on a case-by-case basis.
 - If the used bentonite slurry is intended to be disposed of through the public drainage system, it should be treated to the respective effluent standards applicable to foul sewers, storm drains or the receiving waters as set out in the Technical Memorandum of Standards for Effluents Discharged into Drainage and Sewerage Systems, Inland and Coastal Waters.
 - If the used bentonite slurry is intended to be disposed to public fill reception facilities, it will be mixed with dry soil on site before disposal.

CONTENTS

6	LANDSCAPE AND VISUAL	6-1
6.1	Introduction	6-1
6.2	Monitoring Details.....	6-1
6.3	Baseline Monitoring.....	6-2
6.4	Event/Action Plan for Landscape and Visual Works	6-2
6.5	Mitigation Measures	6-4

LIST OF TABLES

Table 6.1	Monitoring Programme
Table 6.2	Construction & Establishment Periods
Table 6.3	Long Term Management

LIST OF FIGURES

Figure 6.1a	Baseline Landscape Resources During Construction
Figure 6.1b	Baseline Landscape Resources During Operation
Figure 6.2a	Baseline Landscape Character Areas During Construction
Figure 6.2b	Baseline Landscape Character Areas During Operation
Figure 6.3a	Key VSRs and Primary Zone of Visual Influence During Construction
Figure 6.3b	Key VSRs and Primary Zone of Visual Influence Operation
Figure 6.3c	Key VSRs and Secondary Zone of Visual Influence

6 LANDSCAPE AND VISUAL

6.1 Introduction

- 6.1.1 The EIA has recommended landscape and visual mitigation measures to be undertaken during both the construction and operational phases of the project. This section outlines the monitoring and audit of these measures.
- 6.1.2 The key landscape resources, landscape character areas and visual sensitive receivers are shown in **Figures 6.1a, 6.1b, 6.2a, 6.2b, 6.3a, 6.3b, 6.3c.**

6.2 Monitoring Details

- 6.2.1 The design, implementation and maintenance of landscape mitigation measures should be checked to ensure that they are fully realised and that potential conflicts between the proposed landscape measures and any other project works and operational requirements are resolved at the earliest possible date and without compromise to the intention of the mitigation measures.

Table 6.1 Monitoring Programme

Stage	Monitoring Task	Monitoring Report	Form of Approval	Frequency
Design	Monitoring of design works against the recommendations of the landscape and visual impact assessments within the EIA should be undertaken during detailed design and tender stages, to ensure that they fulfil the intentions of the mitigation measures. Any changes to the design, including design changes on site should also be checked.	Report by ER confirming that the design conforms to requirements of EP	Approved by Client	At Completion of Design Stage
Construction	Monitoring of the contractor's operations during the construction period.	Report on Contractor's compliance, by ET	Counter-signature of report by IEC	Weekly
Establishment Works	Monitoring of the planting works during the 24-month Establishment period after completion of the construction works.	Report on Contractor's compliance, by ET	Counter-signature of report by IEC	3 months
Long Term Operation (5 years)	Monitoring of the long-term management of the planting works in the period up to 5 years after completion of the construction works.	Report on compliance by ET or Maintenance Agency	Counter-signature of report by Management Agency	12 months

Design

- 6.2.2 The mitigation measures proposed within the EIA to mitigate the landscape and visual impacts of the scheme should be embodied into the detailed engineering design and landscape design drawings and contract documents. Designs should be checked to ensure that the measures are fully incorporated and that potential conflicts with civil engineering, geo-technical, structural, lighting, signage, drainage, underground utility and operational requirements are resolved prior to construction.
- 6.2.3 The Client should prepare a detailed 5-Year Management Programme for the long-term management and maintenance of the planting works following the Establishment periods. The Programme should include evaluation and objectives for management, details of the operations to be undertaken to achieve these objectives, and outline of work programmes.

Construction & Establishment Period

- 6.2.4 The implementation of landscape construction works and subsequent maintenance operations during the 12-month establishment period must be supervised by fully qualified Landscape Resident Site Staff (Registered Landscape Architect or Professional Member of the Hong Kong Institute of landscape Architects).
- 6.2.5 Measures to mitigate landscape and visual impacts during construction should be checked to ensure compliance with the intended aims of the measures.
- 6.2.6 The progress of the engineering works shall be regularly reviewed on site to identify the earliest practical opportunities for the landscape works to be undertaken.

Long Term Management

- 6.2.7 The success or otherwise of all planting works intended to mitigate the visual and landscape impact of the roads, the noise barriers/screening/semi-enclosures and street lighting shall be monitored during the first ten years of the operational phase of the project. Any areas of vegetation which have failed to establish, should be corrected by the appropriate maintenance authorities at the earliest opportunity. Monitoring should include the long-term maintenance of the planting works under the detailed 5-Year Management Programme.

6.3 Baseline Monitoring

- 6.3.1 A photographic record of the site at the time of the contractor's possession of the site shall be prepared by the Contractor and approved by the ER. The approved photographic Record shall be submitted to the Project proponent, ET, IEC and EPD for record.

6.4 Event/Action Plan for Landscape and Visual Works

- 6.4.1 Should non-compliance of the landscape and visual impacts occur, actions in accordance with the action plan stated in **Table 6.2** and **6.3** should be carried out.

Table 6.2 Construction & Establishment Periods

Event Action level	Action			
	ET	IEC	ER	Contractor
Design Check	<ul style="list-style-type: none"> Check final design conforms to the requirements of EP and prepare report. 	<ul style="list-style-type: none"> Check report. Recommend remedial design if necessary 	<ul style="list-style-type: none"> Undertake remedial design if necessary 	
Non-conformity on one occasion	<ul style="list-style-type: none"> Identify Source Inform IEC and ER Discuss remedial actions with IEC, ER and Contractor Monitor remedial actions until rectification has been completed 	<ul style="list-style-type: none"> Check report Check Contractor's working method Discuss with ET and Contractor on possible remedial measures Advise ER on effectiveness of proposed remedial measures. Check implementation of remedial measures. 	<ul style="list-style-type: none"> Notify Contractor Ensure remedial measures are properly implemented 	<ul style="list-style-type: none"> Amend working methods Rectify damage and undertake any necessary replacement
Repeated Non-conformity	<ul style="list-style-type: none"> Identify Source Inform IEC and ER Increase monitoring frequency Discuss remedial actions with IEC, ER and Contractor Monitor remedial actions until rectification has been completed If non-conformity stops, cease additional monitoring 	<ul style="list-style-type: none"> Check monitoring report Check Contractor's working method Discuss with ET and Contractor on possible remedial measures Advise ER on effectiveness of proposed remedial measures Supervise implementation of remedial measures. 	<ul style="list-style-type: none"> Notify Contractor Ensure remedial measures are properly implemented 	<ul style="list-style-type: none"> Amend working methods Rectify damage and undertake any necessary replacement

Table 6.3 Long Term Management

Event Action Level	Action			
	Maintenance Agency	Management Agency		
Non-conformity	<ul style="list-style-type: none"> Identify Source Discuss remedial actions with Management Agency Monitor remedial actions until rectification has been completed 	<ul style="list-style-type: none"> Check report Discuss with Maintenance Agency possible remedial measures Supervise implementation of remedial measures. 		

6.5 Mitigation Measures

6.5.1 The landscape and visual impact assessment of the EIA recommends a series on mitigation measures, as noted below:

Landscape and Visual Mitigation Measures during Construction Phase

- Topsoil, where identified, should be stripped and stored for re-use in the construction of the soft landscape works, where practical (CM1);
- Existing trees to be retained on site should be carefully protected during construction (CM2);
- Trees unavoidably affected by the works should be transplanted where practical (CM3);
- Compensatory tree planting should be provided to compensate for felled trees (CM4);
- Control of night-time lighting (CM5);
- Erection of decorative screen hoarding compatible with the surrounding setting (CM6).

Landscape and Visual Mitigation Measures during Operation Phase

- Aesthetic design of buildings and road-related structures, including viaducts, vent buildings, subways, footbridges and noise barriers and enclosure (OM1);
- Shrub and Climbing Plants to soften proposed structures (OM2);
- Buffer Tree and Shrub Planting to screen proposed roads and associated structures (OM3);
- Aesthetic streetscape design (OM5);
- Aesthetic design of roadside amenity areas (OM6).

CONTENTS

9 SITE ENVIRONMENTAL AUDIT..... 9-1

9.1 Site Inspections 9-1

9.2 Compliance with Legal and Contractual Requirements 9-1

9.3 Environmental Complaints..... 9-2

9 SITE ENVIRONMENTAL AUDIT

9.1 Site Inspections

- 9.1.1 Site inspections provide a direct means to initiate and enforce specified environmental protection and pollution control measures. These shall be undertaken routinely to inspect construction activities in order to ensure that appropriate environmental protection and pollution control mitigation measures are properly implemented. The site inspection is one of the most effective tools to enforce the environmental protection requirements at the works area.
- 9.1.2 The ET Leader shall be responsible for formulating the environmental site inspection, the deficiency and action reporting system, and for carrying out the site inspection works. Within 21 days of the construction contract commencement, he shall submit a proposal for site inspection and deficiency and action reporting procedures to the Contractor for agreement, and to the ER for approval. The ET's proposal for rectification would be made known to the IEC.
- 9.1.3 Regular site inspections shall be carried out at least once per week. The inspection shall not be limited to the environmental situation, pollution control and mitigation measures within the site; it should also review the environmental situation outside the works area which is likely to be affected, directly or indirectly, by the site activities. The ET Leader shall make reference to the following information in conducting the inspection:
- (i) EIA recommendations on environmental protection and pollution control mitigation measures;
 - (ii) works progress and programme;
 - (iii) individual works methodology proposals (which shall include proposal on associated pollution control measures);
 - (iv) contract specifications on environmental protection;
 - (v) relevant environmental protection and pollution control laws; and
 - (vi) previous site inspection results.
- 9.1.4 The Contractor shall keep the ET Leader updated with all relevant information on the construction contract necessary for him to carry out site inspections. Inspection results and associated recommendations for improvements to the environmental protection and pollution control works shall be submitted to the IEC and the Contractor within 24 hours. The Contractor shall follow the procedures and time-frame as stipulated in the environmental site inspection, and the deficiency and action reporting system formulated by the ET Leader, to report on any remedial measures subsequent to the site inspections.
- 9.1.5 Ad hoc site inspections shall also be carried out if significant environmental problems are identified. Inspections may also be required subsequent to receipt of an environmental complaint, or as part of the investigation work, as specified in the Action Plan for environmental monitoring and audit.

9.2 Compliance with Legal and Contractual Requirements

- 9.2.1 There are contractual environmental protection and pollution control requirements as well as environmental protection and pollution control laws in Hong Kong with which construction activities must comply.
- 9.2.2 In order that the works are in compliance with the contractual requirements, all works method statements submitted by the Contractor to the ER for approval shall be sent to the ET Leader for

vetting to see whether sufficient environmental protection and pollution control measures have been included. The implementation schedule of mitigation measures is summarised in Appendix A.

- 9.2.3 The ET Leader shall also review the progress and programme of the works to check that relevant environmental laws have not been violated, and that any foreseeable potential for violating laws can be prevented.
- 9.2.4 The Contractor shall regularly copy relevant documents to the ET Leader so that works checking can be carried out. The document shall at least include the updated Works Progress Reports, updated Works Programme, any application letters for different licence / permits under the environmental protection laws, and copies of all valid licences / permits. The site diary shall also be available for the ET Leader's inspection upon his request.
- 9.2.5 After reviewing the document, the ET Leader shall advise the IEC and Contractor of any non-compliance with contractual and legislative requirements on environmental protection and pollution control for them to take follow-up actions. If the ET Leader's review concludes that the current status on licence / permit application and any environmental protection and pollution control preparation works may result in potential violation of environmental protection and pollution control requirements, he shall also advise the Contractor and the ER accordingly.
- 9.2.6 Upon receipt of the advice, the Contractor shall undertake immediate action to correct the situation. The ER shall follow up to ensure that appropriate action has been taken in order to satisfy contractual and legal requirements.

9.3 Environmental Complaints

- 9.3.1 Complaints shall be referred to the ET Leader for action. The ET Leader shall undertake the following procedures upon receipt of any complaint:
- (i) log complaint and date of receipt onto the complaint database and inform the IEC and ER immediately;
 - (ii) investigate the complaint to determine its validity, and assess whether the source of the problem is due to works activities;
 - (iii) identify mitigation measures in consultation with the IEC if a complaint is valid and due to works;
 - (iv) advise the Contractor if mitigation measures are required;
 - (v) review the Contractor's response to identified mitigation measures, and the updated situation;
 - (vi) if the complaint is transferred from the EPD, submit interim report to the EPD on status of the complaint investigation and follow-up action within the time frame assigned by the EPD;
 - (vii) undertake additional monitoring and audit to verify the situation if necessary, and review the circumstances leading to the complaint (to ensure that any short comings) do not recur;
 - (viii) report investigation results and subsequent actions to complainant (if the source of complaint is EPD, the results should be reported within the timeframe assigned by the EPD); and
 - (ix) record the complaint, investigation, the subsequent actions and the results in the monthly EM&A reports.
- 9.3.2 During any complaint investigation work, the Contractor and ER shall co-operate with the ET Leader in providing all necessary information and assistance for completion of the investigation. If

mitigation measures are identified as being required in the investigation, the Contractor shall promptly carry out the mitigation. The ER shall ensure that all necessary measures have been carried out by the Contractor.

CONTENTS

10 REPORTING 10-1

- 10.1 General 10-1
- 10.2 Baseline Monitoring Report 10-1
- 10.3 Monthly EM&A Reports..... 10-2
- 10.4 Quarterly EM&A Summary Reports 10-6
- 10.5 Final EM&A Review Reports 10-7
- 10.6 Data Keeping 10-8
- 10.7 Interim Notifications of Environmental Quality Limit Exceedances 10-8

10 REPORTING

10.1 General

- 10.1.1 Reports can be provided in an electronic medium upon agreeing the format with the ER and EPD. This would enable a transition from a paper / historic and reactive approach to an electronic / real time proactive approach. All the monitoring data (baseline and impact) shall also be submitted in diskettes. The format for air quality and noise monitoring data to be submitted in diskette is shown in Appendices B1 and B2.
- 10.1.2 Types of reports that the ET Leader shall prepare and submit include baseline monitoring report, monthly EM&A report, quarterly EM&A summary report and final EM&A review report. In accordance with Annex 21 of the EIAO-TM, a copy of the monthly, quarterly summary and final review EM&A reports shall be made available to the Director of Environmental Protection.

10.2 Baseline Monitoring Report

- 10.2.1 The ET Leader shall prepare and submit a Baseline Environmental Monitoring Report within 10 working days of completion of the baseline monitoring. Copies of the Baseline Environmental Monitoring Report shall be submitted to the Contractor, the IEC, the ER and the EPD. The ET Leader shall liaise with the relevant parties on the exact number of copies they require. The report format and baseline monitoring data format shall be agreed with the EPD prior to submission.
- 10.2.2 The baseline monitoring report shall include at least the following:
- (i) up to half a page executive summary;
 - (ii) brief project background information;
 - (iii) drawings showing locations of the baseline monitoring stations;
 - (iv) monitoring results (in both hard and diskette copies) together with the following information:
 - monitoring methodology;
 - name of laboratory and types of equipment used and calibration details;
 - parameters monitored;
 - monitoring locations;
 - monitoring date, time, frequency and duration; and
 - quality assurance (QA) / quality control (QC) results and detection limits.

- (v) details of influencing factors, including:
 - major activities, if any, being carried out on the site during the period;
 - weather conditions during the period; and
 - other factors which might affect results;
- (vi) determination of the Action and Limit Levels for each monitoring parameter and statistical analysis of the baseline data, the analysis shall conclude if there is any significant difference between control and impact stations for the parameters monitored;
- (vii) revisions for inclusion in the EM&A Manual; and
- (viii) comments, recommendations and conclusions.

10.3 Monthly EM&A Reports

- 10.3.1 The results and findings of all EM&A work required in the Manual shall be recorded in the monthly EM&A reports prepared by the ET Leader. The EM&A report shall be prepared and submitted within 10 working days of the end of each reporting month, with the first report due the month after construction commences. Each monthly EM&A report shall be submitted to the following parties: the Contractor, the IEC, the ER and the EPD. Before submission of the first EM&A report, the ET Leader shall liaise with the parties on the required number of copies and format of the monthly reports in both hard copy and electronic medium.
- 10.3.2 The ET leader shall review the number and location of monitoring stations and parameters every six months, or on as needed basis, in order to cater for any changes in the surrounding environment and the nature of works in progress.

First Monthly EM&A Report

- 10.3.3 The first monthly EM&A report shall include at least the following :

- (i) executive summary (1 - 2 pages):
 - breaches of Action and Limit levels;
 - complaint log;
 - notifications of any summons and successful prosecutions;
 - reporting changes; and
 - future key issues.
- (ii) basic project information:
 - project organisation including key personnel contact names and telephone numbers;
 - programme;
 - management structure, and
 - work undertaken during the month;
- (iii) environmental status:

- works undertaken during the month with illustrations (such as location of works, daily excavation rate, etc); and
 - drawing showing the project area, any environmental sensitive receivers and the locations of the monitoring and control stations (with co-ordinates of the monitoring locations);
- (iv) a brief summary of EM&A requirements including:
- all monitoring parameters;
 - environmental quality performance limits (Action and Limit levels);
 - Event-Action Plans;
 - environmental mitigation measures, as recommended in the project EIA report; and
 - environmental requirements in contract documents;
- (v) implementation status:
- advice on the implementation status of environmental protection and pollution control / mitigation measures, as recommended in the project EIA;
- (vi) monitoring results (in both hard and diskette copies) together with the following information:
- monitoring methodology;
 - name of laboratory and types of equipment used and calibration details;
 - parameters monitored;
 - monitoring locations;
 - monitoring date, time, frequency, and duration;
 - weather conditions during the period;
 - any other factors which might affect the monitoring results; and
 - QA/QC results and detection limits;
- (vii) report on non-compliance, complaints, and notifications of summons and successful prosecutions:
- record of all non-compliance (exceedances) of the environmental quality performance limits (Action and Limit levels);
 - record of all complaints received (written or verbal) for each media, including locations and nature of complaints investigation, liaison and consultation undertaken, actions and follow-up procedures taken, results and summary;
 - record of all notification of summons and successful prosecutions for breaches of current environmental protection / pollution control legislation, including locations and nature of the breaches, investigation, follow-up actions taken, results and summary;
 - review of the reasons for and the implications of non-compliance, complaints, summons and prosecutions including review of pollution sources and working procedures; and

- description of the actions taken in the event of non-compliance and deficiency reporting and any follow-up procedures related to earlier non-compliance;
- (viii) others
- an account of the future key issues as reviewed from the works programme and work method statements;
 - advice on the solid and liquid waste management status; and
 - comments (for example, effectiveness and efficiency of the mitigation measures), recommendations (for example, any improvement in the EM&A programme) and conclusions.

Subsequent EM&A Reports

10.3.4 Subsequent monthly EM&A reports shall include the following:

- (i) executive summary (1 - 2 pages):
- breaches of Action and Limit levels;
 - complaints log;
 - notifications of any summons and successful prosecutions;
 - reporting changes; and
 - future key issues.
- (ii) basic project information:
- project organisation including key personnel contact names and telephone numbers;
 - programme;
 - management structure; and
 - work undertaken during the month.
- (iii) environmental status:
- works undertaken during the month with illustrations (such as location of works, daily excavation rate, etc.); and
 - drawing showing the project area, any environmental sensitive receivers and the locations of the monitoring and control stations.
- (iv) implementation status:
- advice on the implementation status of environmental protection and pollution control / mitigation measures, as recommended in the project EIA.
- (v) monitoring results (in both hard and diskette copies) together with the following information:
- monitoring methodology;

- name of laboratory and types of equipment used and calibration details;
 - parameters monitored;
 - monitoring locations;
 - monitoring date, time, frequency, and duration;
 - weather conditions during the period;
 - any other factors which might affect the monitoring results; and
 - QA/QC results and detection limits.
- (vi) report on non-compliance, complaints, and notifications of summons and successful prosecutions:
- record of all non-compliance (exceedances) of the environmental quality performance limits (Action and Limit levels);
 - record of all complaints received (written or verbal) for each media, including locations and nature of complaints investigation, liaison and consultation undertaken, actions and follow-up procedures taken, results and summary;
 - record of all notification of summons and successful prosecutions for breaches of current environmental protection / pollution control legislation, including locations and nature of the breaches, investigation, follow-up actions taken, results and summary;
 - review of the reasons for and the implications of non-compliance, complaints, summons and prosecutions including review of pollution sources and working procedures; and
 - description of the actions taken in the event of non-compliance and deficiency reporting and any follow-up procedures related to earlier non-compliance.
- (vii) others
- an account of the future key issues as reviewed from the works programme and work method statements;
 - advice on the solid and liquid waste management status; and
 - comments (for example, effectiveness and efficiency of the mitigation measures), recommendations (for example, any improvement in the EM&A programme) and conclusions.
- (viii) appendix
- Action and Limit levels;
 - graphical plots of trends of monitored parameters at key stations over the past four reporting periods for representative monitoring stations annotated against the following:
 - a) major activities being carried out on site during the period;
 - b) weather conditions during the period; and
 - c) any other factors that might affect the monitoring results.

- monitoring schedule for the present and next reporting period;
- cumulative statistics on complaints, notifications of summons and successful prosecutions; and
- outstanding issues and deficiencies.

10.4 Quarterly EM&A Summary Reports

10.4.1 A quarterly EM&A summary report of around 5 pages shall be produced and shall contain at least the following information:

- (i) executive summary (1 - 2 pages);
- (ii) basic project information including a synopsis of the project organisation, programme, contacts of key management, and a synopsis of work undertaken during the quarter;
- (iii) a brief summary of EM&A requirements including:
 - monitoring parameters;
 - environmental quality performance limits (Action and Limit levels); and
 - environmental mitigation measures, as recommended in the project EIA Final Report;
- (iv) advice on the implementation status of environmental protection and pollution control / mitigation measures, as recommended in the project EIA Report, summarised in the updated implementation schedule;
- (v) drawings showing the project area, any environmental sensitive receivers and the locations of the monitoring and control stations;
- (vi) graphical plots of any trends in monitored parameters over the past four months (the last month of the previous quarter and the present quarter) for representative monitoring stations annotated against:
 - the major activities being carried out on site during the period;
 - weather conditions during the period; and
 - any other factors which might affect the monitoring results;
- (vii) advice on the solid and liquid waste management status;
- (viii) a summary of non-compliance (exceedance) of the environmental quality performance limits (Action and Limit levels);
- (ix) a brief review of the reasons for and the implications of any non-compliance, including a review of pollution sources and working procedures;
- (x) a summary description of actions taken in the event of non-compliance and any follow-up procedures related to any earlier non-compliance;
- (xi) a summarised record of all complaints received (written or verbal) for each media, liaison and consultation undertaken, actions and follow-up procedures taken;

- (xii) comments (for example, a review of the effectiveness and efficiency of the mitigation measures and the performance of the environmental management system, that is, of the overall EM&A programme); recommendations (for example, any improvement in the EM&A programme) and conclusions for the quarter; and
- (xiii) proponents' contacts and any hotline telephone number for the public to make enquiries.

10.5 Final EM&A Review Reports

10.5.1 The final EM&A report should contain at least the following information:

- (i) executive summary (1 - 2 pages);
- (ii) drawings showing the project area, any environmental sensitive receivers and the locations of the monitoring and control stations;
- (iii) basic project information including a synopsis of the project organisation, contacts of key management, and a synopsis of work undertaken during the course of the project or past twelve months;
- (iv) a brief summary of EM&A requirements including:
 - environmental mitigation measures, as recommended in the project EIA Report;
 - environmental impact hypotheses tested;
 - environmental quality performance limits (Action and Limit levels);
 - all monitoring parameters;
 - Event-Action Plans.
- (v) a summary of the implementation status of environmental protection and pollution control / mitigation measures, as recommended in the project EIA Report, summarised in the updated implementation schedule;
- (vi) graphical plots and the statistical analysis of the trends of monitored parameters over the course of the project, including the post-project monitoring (or the past twelve months for annual reports) for all monitoring stations annotated against:
 - the major activities being carried out on site during the period;
 - weather conditions during the period; and
 - any other factors which might affect the monitoring results;
- (vii) a summary of non-compliance (exceedances) of the environmental quality performance limits (Action and Limit levels);
- (viii) a review of the reasons for and the implications of non-compliance including review of pollution sources and working procedures as appropriate;
- (ix) a description of the actions taken in the event of non-compliance;
- (x) a summary record of all complaints received (written or verbal) for each media, liaison and consultation undertaken, actions and follow-up procedures taken;

- (xi) a summary record of notifications of summons and successful prosecutions for breaches of the current environmental protection / pollution control legislation, locations and nature of the breaches, investigation follow-up actions taken and results;
- (xii) a review of the validity of EIA predictions and identification of shortcomings in EIA recommendations; and
- (xiii) comments (for example, a review of the effectiveness and efficiency of the mitigation measures and of the performance of the environmental management system, that is, of the overall EM&A programme);
- (xix) recommendations and conclusions (for example, a review of success of the overall EM&A programme to cost-effectively identify deterioration and to initiate prompt effective mitigatory action when necessary).

10.6 Data Keeping

- 10.6.1 No site-based documents (such as monitoring field records, laboratory analysis records, site inspection forms, etc.) are required to be included in the monthly EM&A reports. However, any such document shall be well kept by the ET Leader and be ready for inspection upon request. All relevant information shall be clearly and systematically recorded in the document. Monitoring data shall also be recorded in magnetic media form, and the software copy must be available upon request. Data format shall be agreed with the EPD. All documents and data shall be kept for at least one year following completion of the construction contract.

10.7 Interim Notifications of Environmental Quality Limit Exceedances

- 10.7.1 With reference to the Event and Action Plan, when the environmental quality performance limits are exceeded, the ET Leader shall immediately notify the IEC and EPD, as appropriate. The notification shall be followed up with advice to IEC and EPD on the results of the investigation, proposed actions and success of the actions taken, with any necessary follow-up proposals. A sample template for the interim notifications is presented in Appendix C.

Figures

LEGEND:

- DP1: TRUNK ROAD IN TUNNEL
- DP1: TRUNK ROAD AT GROUND LEVEL
- DP1: SLIP ROAD IN TUNNEL
- DP1: SLIP ROAD AT GROUND LEVEL
- DP1: ELEVATED ROAD

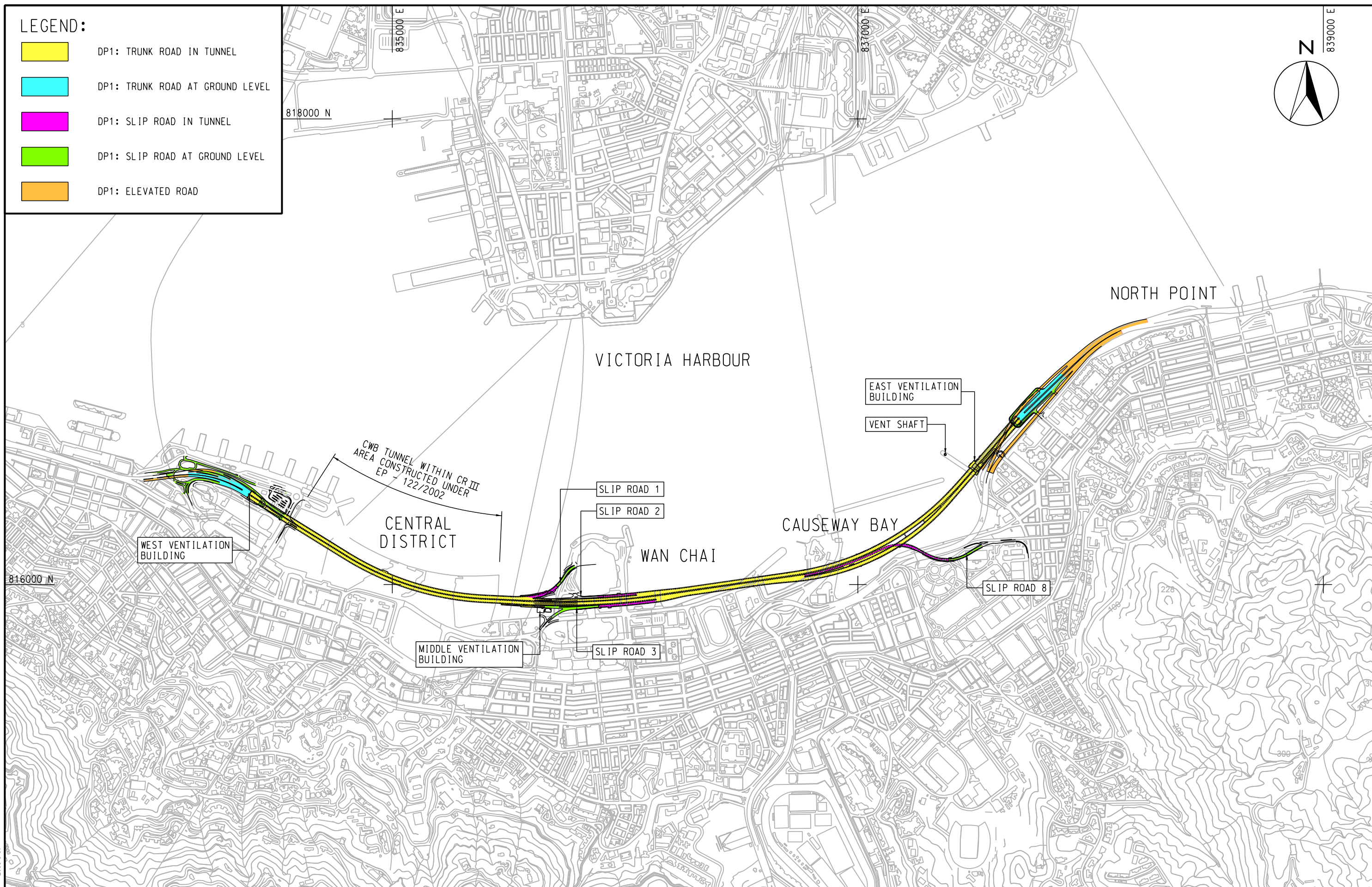

CENTRAL - WAN CHAI BYPASS AND IEC LINK

**DESIGNATED PROJECT 1 (DP1) - CENTRAL - WAN CHAI BYPASS (CWB)
INCLUDING ITS ROAD TUNNEL AND SLIP ROADS**



SCALE	A3 1 : 15000	DATE	--
CHECK	--	DRAWN	NHP
JOB No.	60095653	DRAWING No.	FIGURE 1.1
		REV	

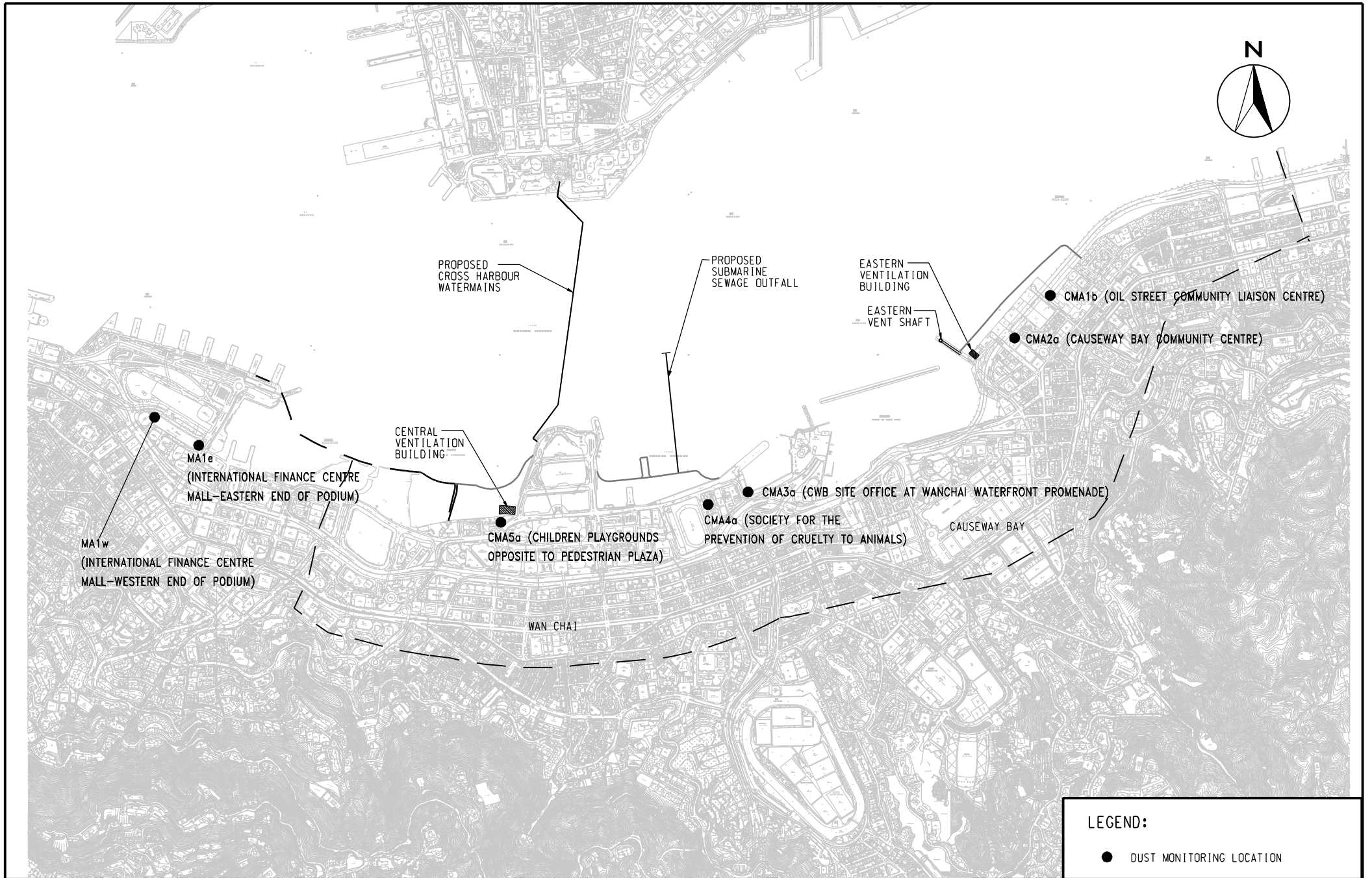

WAN CHAI DEVELOPMENT PHASE II - PLANNING AND ENGINEERING REVIEW
 LOCATIONS OF AIR QUALITY MONITORING STATIONS

FIGURE 2.1

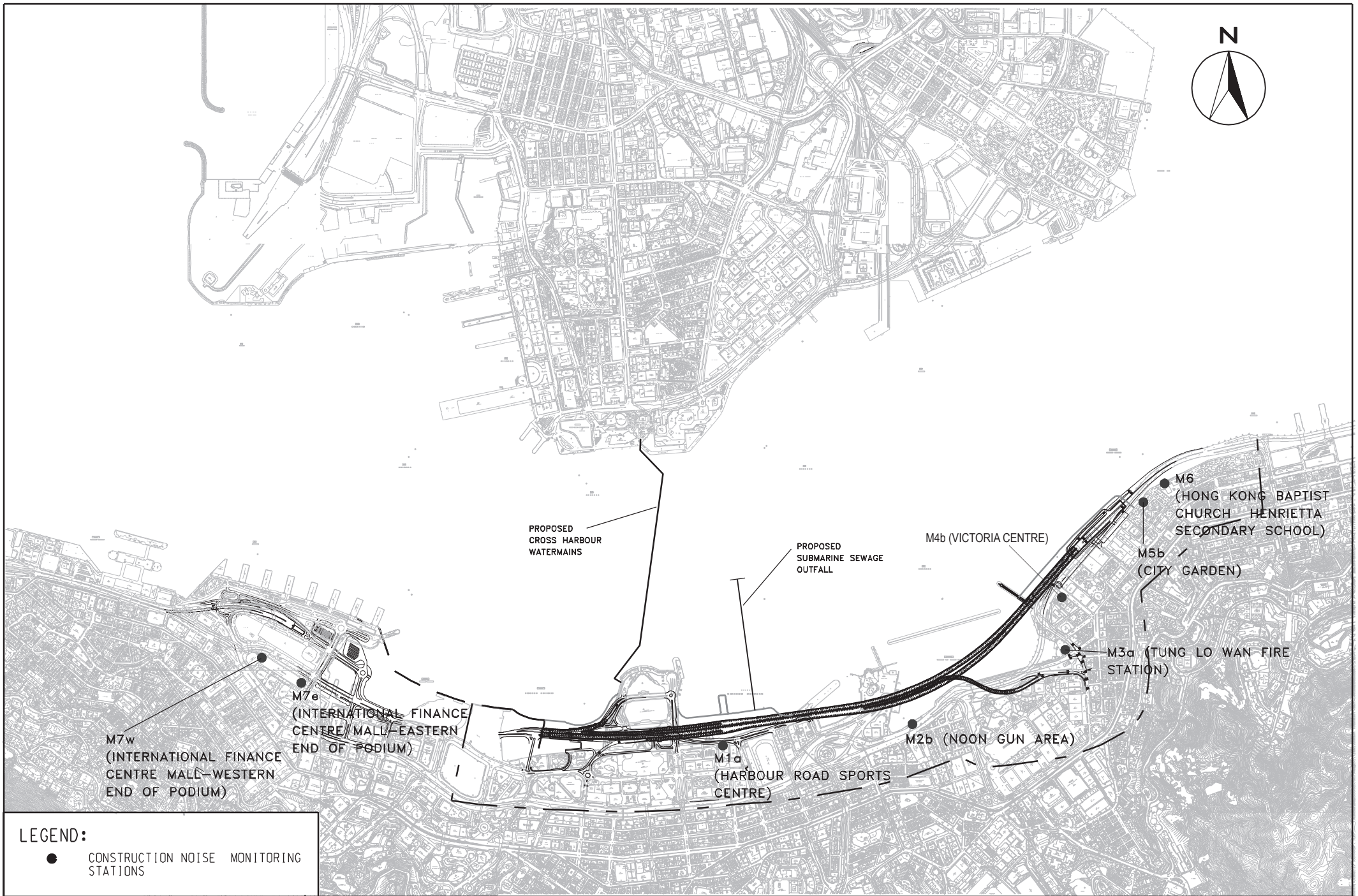

WANCHAI DEVELOPMENT PHASE II - PLANNING AND ENGINEERING REVIEW





LOCATIONS OF NOISE MONITORING STATIONS

FIGURE 3.1

KEY FOR LANDSCAPE RESOURCES

- LR1 Natural Coastline at the RHKYC at Kelllett Island
- LR1A Victoria Harbour
- LR2 Academy Podium Garden
- LR3 Fenwick Pier Street Public Open Space
- LR4 Grand Hyatt Hotel Public Podium Plaza
- LR5 Hong Kong Convention and Exhibition Centre Promenade
- LR6 Renaissance Harbour View Hotel Eastern Boundary Landscaping
- LR7 Central Plaza Open Space
- LR8 Harbour Road Garden
- LR9 Gloucester Road Tree Planting Including Cross Harbour Tunnel Entrance Area
- LR9A Tunnel Approach Rest Garden
- LR10 Tree Planting adjacent to Sewage Works, Hung Hing Road
- LR11 Royal Hong Kong Yacht Club
- LR12 Tree Planting to Southern Boundary of the Police Officers' Club
- LR13 Waterfront area along Causeway Bay Typhoon Shelter
- LR14 Victoria Park
- LR15 Harcourt Garden
- LR16 Wan Chai Sports Ground
- LR17 Noon Day Gun
- LR18 Floating Tin Hau Temple
- LR19 Typhoon Shelter
- LR20 Street trees along Convention Avenue and Hung Hing Road
- LR21 Tung Lo Wan Garden
- LR22 Amenity areas between Fenwick Pier Street and Harbour Road

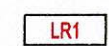
LEGEND

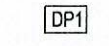
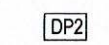
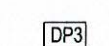
-  PLANNING AND ENGINEERING REVIEW STUDY AREA BOUNDARY
-  LANDSCAPE IMPACT STUDY BOUNDARY
-  LANDSCAPE RESOURCES
-  PHOTO TAKING POINT WITH PHOTO NO.
-  CENTRAL-WANCHAI BYPASS (CWB) INCLUDING ITS ROAD TUNNEL AND SLIP ROADS
-  ROAD P2 AND OTHER ROADS WHICH ARE CLASSIFIED AS PRIMARY/DISTRICT DISTRIBUTOR ROADS
-  RECLAMATION WORKS INCLUDING ASSOCIATED DREDGING WORKS

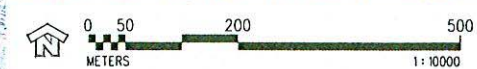
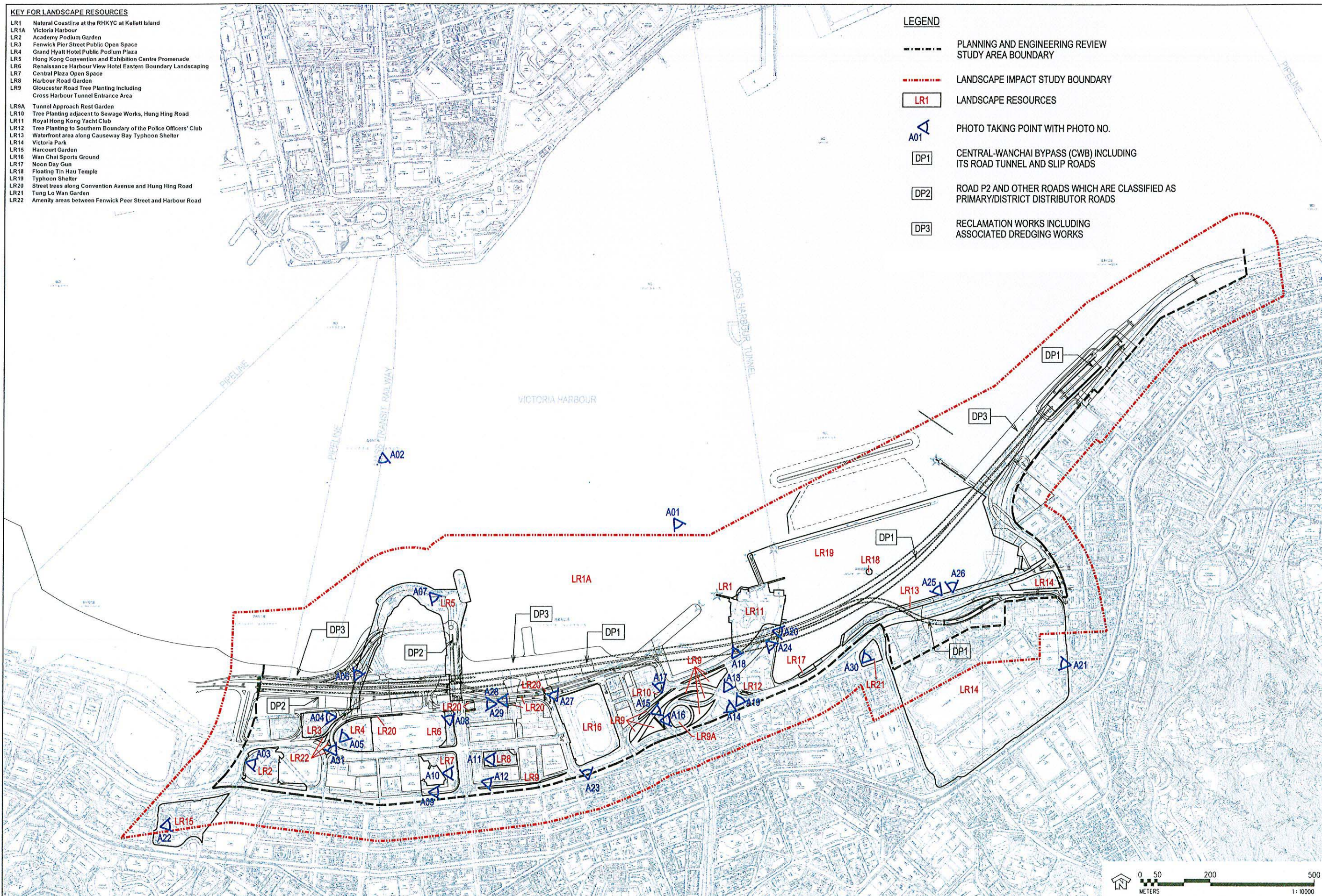

KEY FOR LANDSCAPE RESOURCES

- LR1 Natural Coastline at the RHKYC at Kellett Island
- LR1A Victoria Harbour
- LR2 Academy Podium Garden
- LR4 Grand Hyatt Hotel Public Podium Plaza
- LR5 Hong Kong Convention and Exhibition Centre Promenade
- LR6 Renaissance Harbour View Hotel
- LR7 Eastern Boundary Landscaping
- LR8 Central Plaza Open Space
- LR8 China Resources Building Garden
- LR9 Gloucester Road Tree Planting including Cross Harbour Tunnel Entrance Area
- LR9A Tunnel Approach Rest Garden
- LR10 Tree Planting adjacent to Sewage Works, Hung Hing Road
- LR11 Royal Hong Kong Yacht Club
- LR12 Tree Planting to Southern Boundary of the Police Officers' Club
- LR13 Waterfront area along Causeway Bay Typhoon Shelter
- LR14 Victoria Park
- LR15 Harcourt Garden
- LR16 Wan Chai Sports Ground
- LR17 Noon Day Gun
- LR18 Floating Tin Hau Temple
- LR19 Typhoon Shelter
- LR20 Street trees along Convention Avenue and Hung Hing Road
- LR21 Tung Lo Wan Garden
- LR22 Amenity Area between Fenwick Peer Street & Harbour Road
- LR23 Planned Open Space for Street Market with Outdoor Performance Area
- LR24 Planned Waterfront Regional Open Space
- LR25 Planned Kiosks and Leisure Boating Area, and Water Sport Centre
- LR26 Planned Waterfront Park

LEGEND



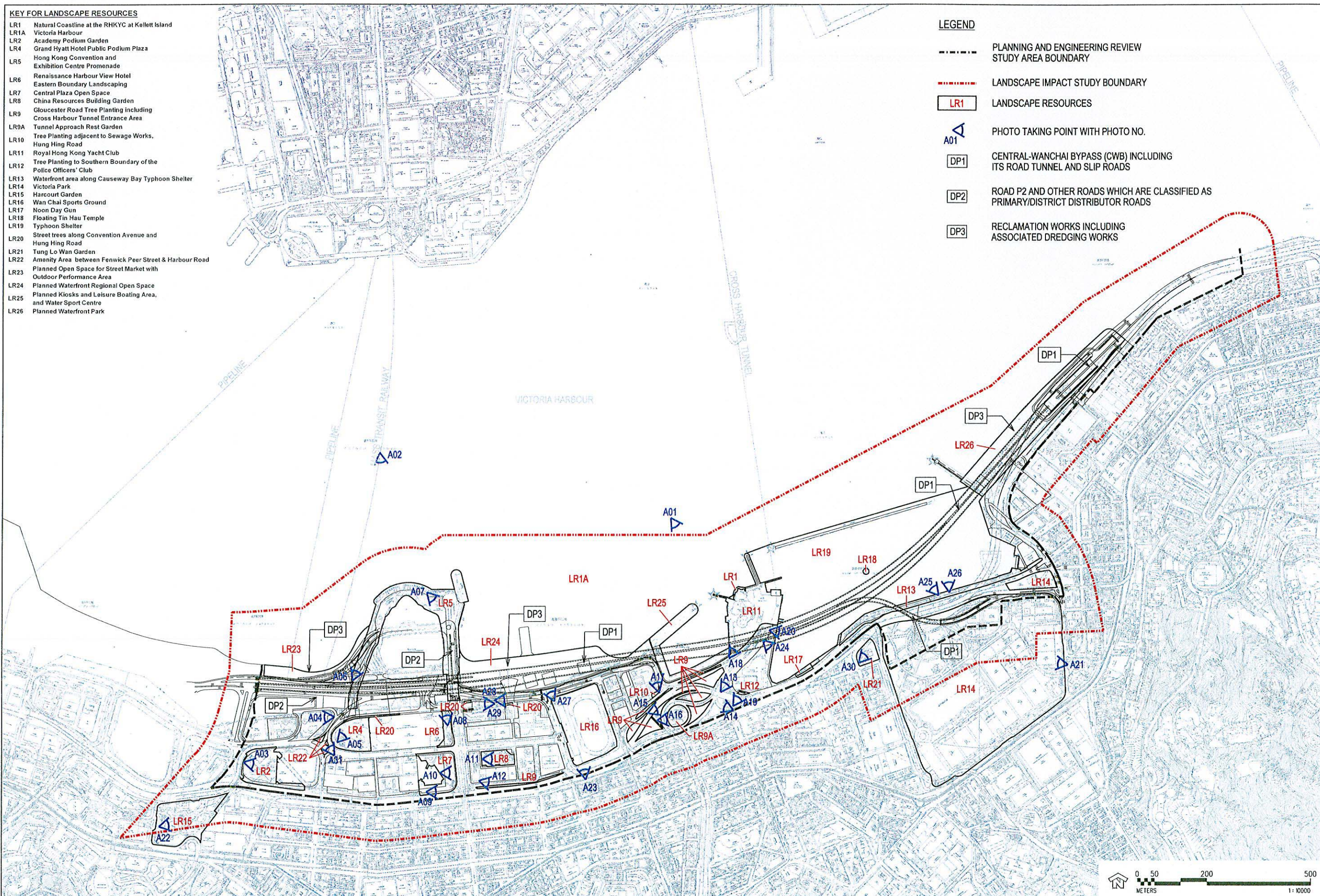

- PLANNING AND ENGINEERING REVIEW STUDY AREA BOUNDARY
- LANDSCAPE IMPACT STUDY BOUNDARY
- LR1 LANDSCAPE RESOURCES
- ▲ A01 PHOTO TAKING POINT WITH PHOTO NO.
- DP1 CENTRAL-WANCHAI BYPASS (CWB) INCLUDING ITS ROAD TUNNEL AND SLIP ROADS
- DP2 ROAD P2 AND OTHER ROADS WHICH ARE CLASSIFIED AS PRIMARY/DISTRICT DISTRIBUTOR ROADS
- DP3 RECLAMATION WORKS INCLUDING ASSOCIATED DREDGING WORKS



KEY FOR LANDSCAPE CHARACTER AREA

- LZ1 Fleet Arcade / Wan Chai West Sewage Screening Plant
- LZ2 The Hong Kong Academy for Performing Arts (HKAPA)
- LZ3 Fenwick Pier Street Public Open Space
- LZ4 The HKCEC Open Space
- LZ5 The HKCEC, Grand Hyatt / Renaissance Harbour View Hotels
- LZ5A Renaissance Harbour View Plaza
- LZ6 The Hong Kong Convention and Exhibition Centre Extension
- LZ6A The Hong Kong Convention and Exhibition Centre Extension Open Space
- LZ7 Government Towers / Shui On Centre
- LZ7A Government Tower Plaza
- LZ8 Central Plaza
- LZ8A Central Plaza Open Space
- LZ9 China Resources Building / Sun Hung Kai Centre
- LZ9A Harbour Road Garden
- LZ10 Great Eagle Centre / Harbour Centre
- LZ11 Public Transport Interchange (PTI)
- LZ12 Harbour Road Sports Centre and Swimming Complex
- LZ13 Wan Chai Ferry Pier
- LZ14 Wan Chai Sports Ground
- LZ15 Society for the Prevention of Cruelty to Animals (SPCA) Building and Utilities
- LZ16 Wanchai Interchange
- LZ16A Tunnel Approach Rest Garden
- LZ17 Ex - Wan Chai Public Cargo Working Area
- LZ18 The Royal Hong Kong Yacht Club (RHKYC)
- LZ19 The Police Officers' Club
- LZ20 The Noon Day Gun and Typhoon Shelter Edge
- LZ21 The Causeway Bay Typhoon Shelter
- LZ22 Shipyard and Fire Station
- LZ23 Gloucester Road / Victoria Park Road
- LZ24 Harbour Road
- LZ25 Convention Avenue
- LZ26 Fleming Road
- LZ27 Tonnochy Road
- LZ28 Marsh Road, Hung Hing Roads, Wan Shing Street
- LZ29 Victoria Harbour
- LZ30 Island Eastern Corridor
- LZ31 Victoria Park

LEGEND

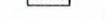
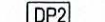

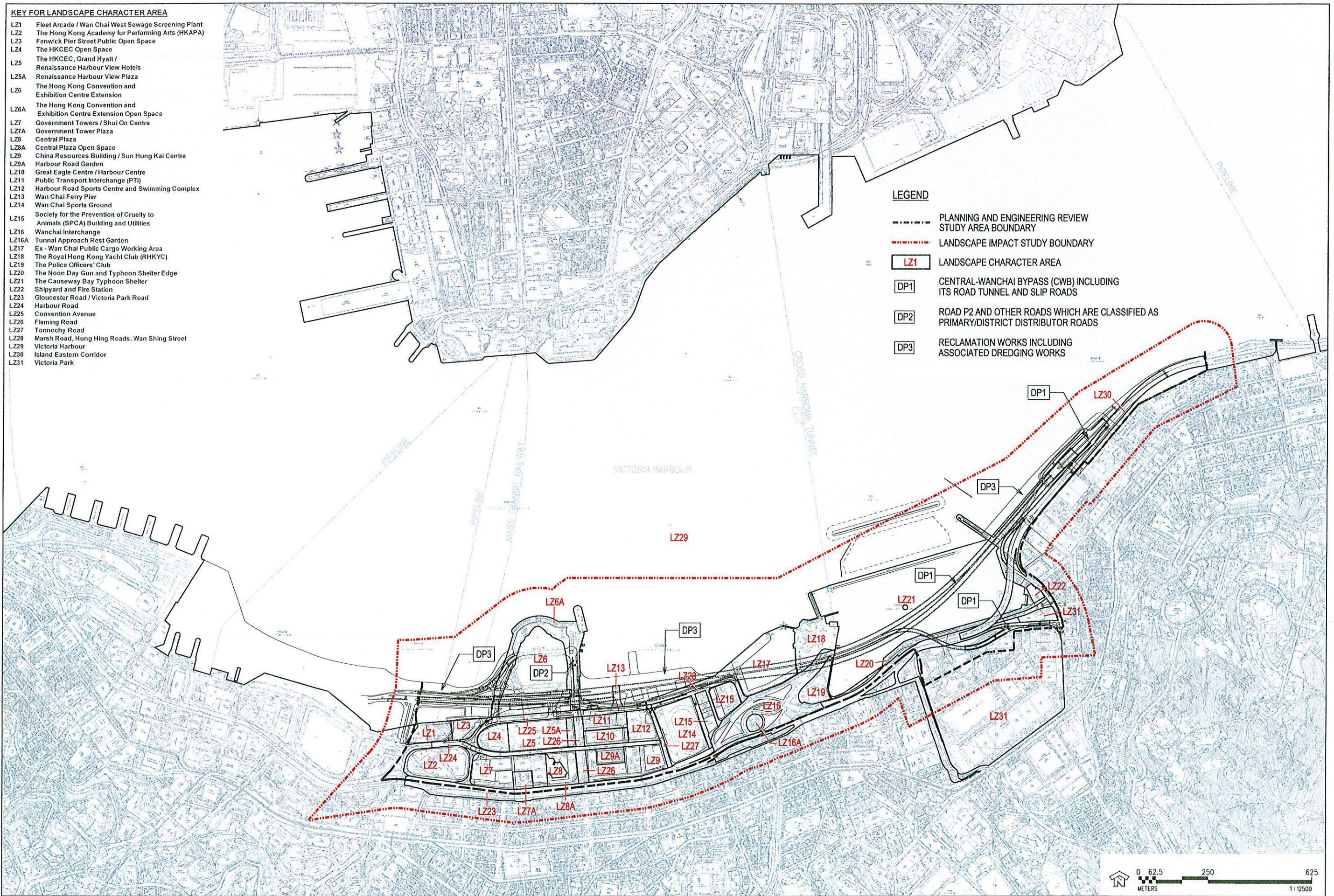

-  PLANNING AND ENGINEERING REVIEW STUDY AREA BOUNDARY
-  LANDSCAPE IMPACT STUDY BOUNDARY
-  LANDSCAPE CHARACTER AREA
-  CENTRAL-WANCHAI BYPASS (CWB) INCLUDING ITS ROAD TUNNEL AND SLIP ROADS
-  ROAD P2 AND OTHER ROADS WHICH ARE CLASSIFIED AS PRIMARY/DISTRICT DISTRIBUTOR ROADS
-  RECLAMATION WORKS INCLUDING ASSOCIATED DREDGING WORKS



KEY FOR LANDSCAPE CHARACTER AREA

- LZ2 The Hong Kong Academy for Performing Arts (HKAPA)
- LZ4 The HKCEC Open Space
- LZ5 The HKCEC, Grand Hyatt / Renaissance Harbour View Hotels
- LZ5A Renaissance Harbour View Plaza
- LZ6 The Hong Kong Convention and Exhibition Centre Extension
- LZ6A The Hong Kong Convention and Exhibition Centre Extension and Open Space
- LZ7 Government Towers / Shui On Centre
- LZ7A Government Tower Plaza
- LZ8 Central Plaza
- LZ8A Central Plaza Open Space
- LZ9 China Resources Building / Sun Hung Kai Centre
- LZ9A Harbour Road Garden
- LZ10 Great Eagle Centre / Harbour Centre
- LZ11 Public Transport Interchange (PTI)
- LZ12 Harbour Road Sports Centre and Swimming Complex
- LZ13 Wan Chai Ferry Pier
- LZ14 Wan Chai Sports Ground
- LZ15 Society for the Prevention of Cruelty to Animals (SPCA) Building and Utilities
- LZ16 Wanchai Interchange
- LZ16A Tunnel Approach Rest Garden
- LZ17 Ex - Wan Chai Public Cargo Working Area
- LZ18 The Royal Hong Kong Yacht Club (RHKYC)
- LZ19 The Police Officers' Club
- LZ20 The Noon Day Gun and Typhoon Shelter Edge
- LZ21 The Causeway Bay Typhoon Shelter
- LZ22 Shipyard and Fire Station
- LZ23 Gloucester Road / Victoria Park Road
- LZ24 Harbour Road
- LZ25 Convention Avenue
- LZ26 Fleming Road
- LZ27 Tonnochy Road
- LZ28 Marsh Road, Hung Hing Roads, Wan Shing Street
- LZ29 Victoria Harbour
- LZ30 Island Eastern Corridor
- LZ31 Victoria Park
- LZ32 Fleet Arcade and Planned HKAPA Extension and Open Space
- LZ33 Planned Open Space for Street Market with Outdoor Performance Area
- LZ34 Planned Waterfront Regional Open Space
- LZ35 Planned Waterfront Park
- LZ36 Planned Regional Open Space

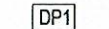
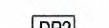
LEGEND

-  PLANNING AND ENGINEERING REVIEW STUDY AREA BOUNDARY
-  LANDSCAPE IMPACT STUDY BOUNDARY
-  LZ1 LANDSCAPE CHARACTER AREA
-  DP1 CENTRAL-WANCHAI BYPASS (CWB) INCLUDING ITS ROAD TUNNEL AND SLIP ROADS
-  DP2 ROAD P2 AND OTHER ROADS WHICH ARE CLASSIFIED AS PRIMARY/DISTRICT DISTRIBUTOR ROADS
-  DP3 RECLAMATION WORKS INCLUDING ASSOCIATED DREDGING WORKS

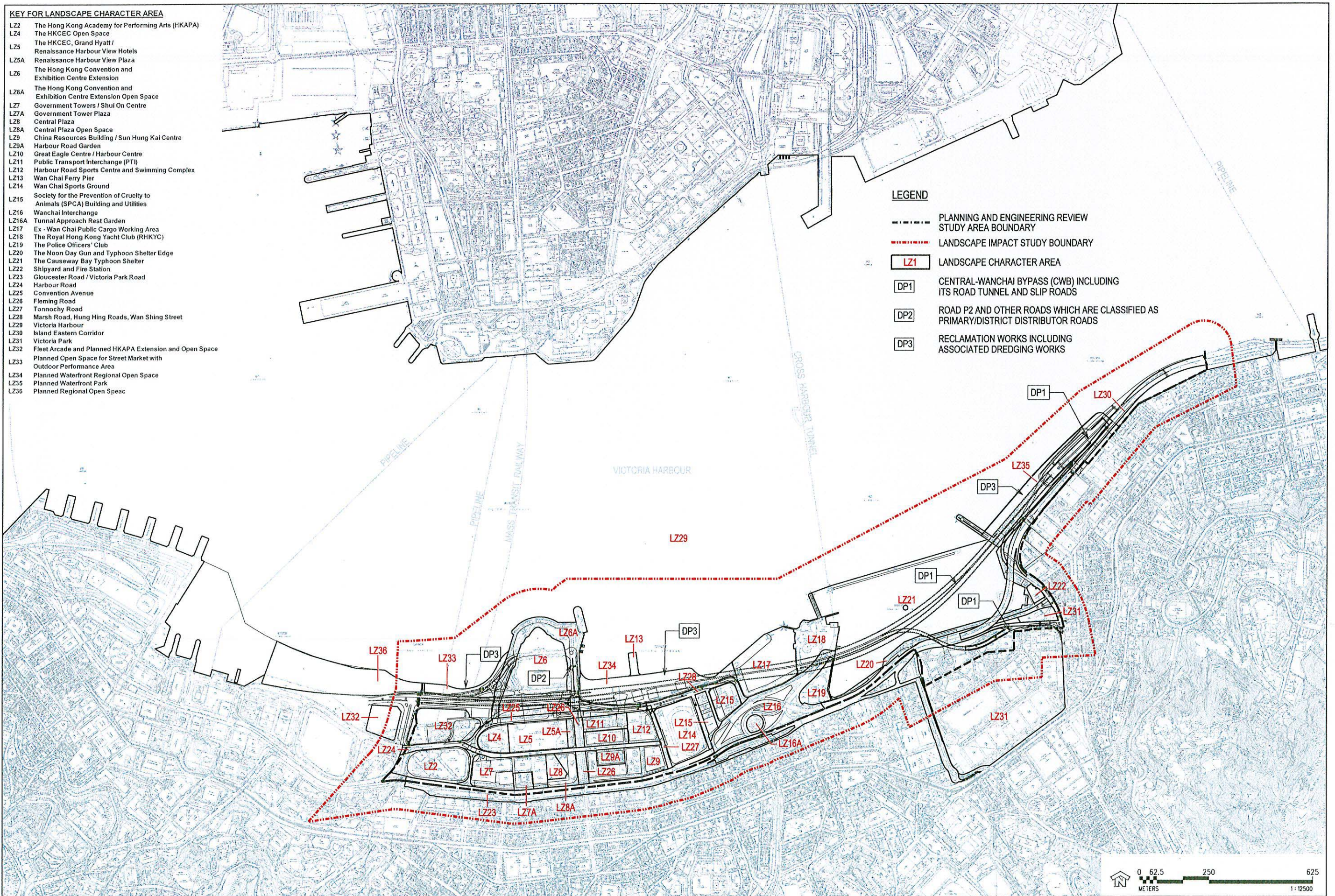

KEY FOR VISUAL SENSITIVE RECEIVERS

- C1 International Finance Centre
- C2 Hong Kong Station Development Phase 2
- C3 Exchange Square
- C4 Jardine House
- C5 Mandarin Hotel
- C6 Hong Kong Club
- C7 Ritz Carlton Hotel
- C8 AIA Tower
- C9 Hutchison House
- C10 Bank of America Tower
- C11 Far East Financial Centre
- C12 Admiralty Centre
- C13 United Centre
- C14 CITIC Tower
- C15 Fleet Arcade
- C16 Asian House
- C17 Chung Nam Building
- C18 Fleet House, Harcourt House
- C19 Telecom House, Hong Kong Arts Centre, Harbour View International House
- C20 Shui On Centre
- C21 Central Plaza
- C22 Grand Hyatt Hotel
- C23 Renaissance Harbour View Hotel
- C24 Hong Kong Convention and Exhibition Centre
- C25 Great Eagle Centre
- C26 Harbour Centre
- C27 China Resources Building
- C28 Sun Hung Kai Centre
- C29 AXA Centre
- C30 Sino Plaza
- C31 World Trade Centre
- C32 Excelsior Hotel
- C33 The Park Lane Hotel
- C34 Windsor House
- C35 19-31 Yee Wo Street
- C36 Citicorp Centre
- C37 Victoria Centre
- C38 Ocean Terminal
- C39 Star House
- C40 Peninsula Hotel
- C41 Sheraton Hotel
- C42 InterContinental Hotel
- C43 New World Centre and Hotel
- C44 Wing On Plaza
- C45 Shangri-La Hotel
- C46 Tsim Sha Tsui Centre
- C47 Empire Centre
- C48 Grand Stanford Harbour View Hotel
- C49 Nikko Hotel
- C50 Four Season Hotel
- C51 Harbour Plaza Metropolis
- C52 AIA Tower
- C53 Newton Hotel
- C54 Electric Centre
- C54A Sea View Estate

- C/R1 Causeway Centre
- C/R2 160-169 Gloucester Road
- C/R3 210-226 Gloucester Road
- C/R4 Elizabeth House
- C/R5 Riviera Mansion
- C/R6 Prospect Mansion
- C/R7 Miami Mansion
- C/R8 Marco Polo Mansion
- C/R9 Victoria Park Mansion
- C/R10 Chesterfield Mansion
- C/R11 Greenfield Mansion
- C/R12 Properties fronting Causeway Road
- C/R13 Park Towers
- C/R14 Viking Garden
- C/R15 50-52 Hing Fat Street
- C/R16 Mayson Garden Building
- C/R17 Gordon House
- C/R18 Belle House
- C/R19 Top Glory Tower
- C/R20 Hoi Kung Court
- C/R21 Hoi To Court
- C/R22 Hoi Deen Court
- C/R23 Pacific Place Complex

- GIC1 General Post Office
- GIC2 City Hall
- GIC3 PLA Headquarters at Tamar
- GIC4 Hong Kong Police Force Headquarters, May House
- GIC5 Revenue Tower
- GIC6 Wan Chai Tower
- GIC7 Police Officers' Club
- GIC8 Queen's College
- GIC9 Hing Fat Street Post Office
- GIC10 Victoria Park School for the Deaf
- GIC11 YMCA
- GIC12 Electric Road Municipal Services Building
- O1 Fenwick Pier Street Public Open Space
- O2 HKCEC Open Space
- O3 HKCEC Extension Open Space and Promenade
- O4 Renaissance Harbour View Plaza
- O5 Central Plaza Open Space
- O6 Wanchai Sports Ground
- O7 Tunnel Approach Rest Garden
- O8 Victoria Park
- O9 Tsim Sha Tsui Waterfront Promenade
- OU1 Royal Hong Kong Yacht Club

- R1 Residential Properties fronting Tung Lo Wan Road
- R4 Harbour Heights
- R5 Residential Properties fronting King Wah Road
- R6 City Garden
- R7 Provident Centre
- S1 Harbour Traffic
- T1 Wanchai North Road Network - vehicular - pedestrian
- T2 Gloucester Road Corridor - vehicular - pedestrian
- T3 Island Eastern Corridor

LEGEND

- PLANNING AND ENGINEERING REVIEW STUDY AREA BOUNDARY
- - - LIMIT OF PRIMARY ZONE OF VISUAL INFLUENCE
- [C1] BOUNDARY OF KEY VSRs
- [C01] PHOTO TAKING POINT WITH PHOTO NO.
- [] COMMERCIAL
- [] COMMERCIAL / RESIDENTIAL
- [] RESIDENTIAL
- [] RECREATIONAL
- [] GOVERNMENT / INSTITUTION / COMMUNITY
- [] TRANSPORT
- [DP1] CENTRAL-WANCHAI BYPASS (CWB) INCLUDING ITS ROAD TUNNEL AND SLIP ROADS
- [DP2] ROAD P2 AND OTHER ROADS WHICH ARE CLASSIFIED AS PRIMARY/DISTRICT DISTRIBUTOR ROADS
- [DP3] RECLAMATION WORKS INCLUDING ASSOCIATED DREDGING WORKS

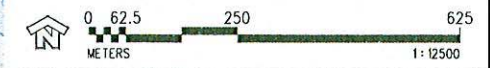
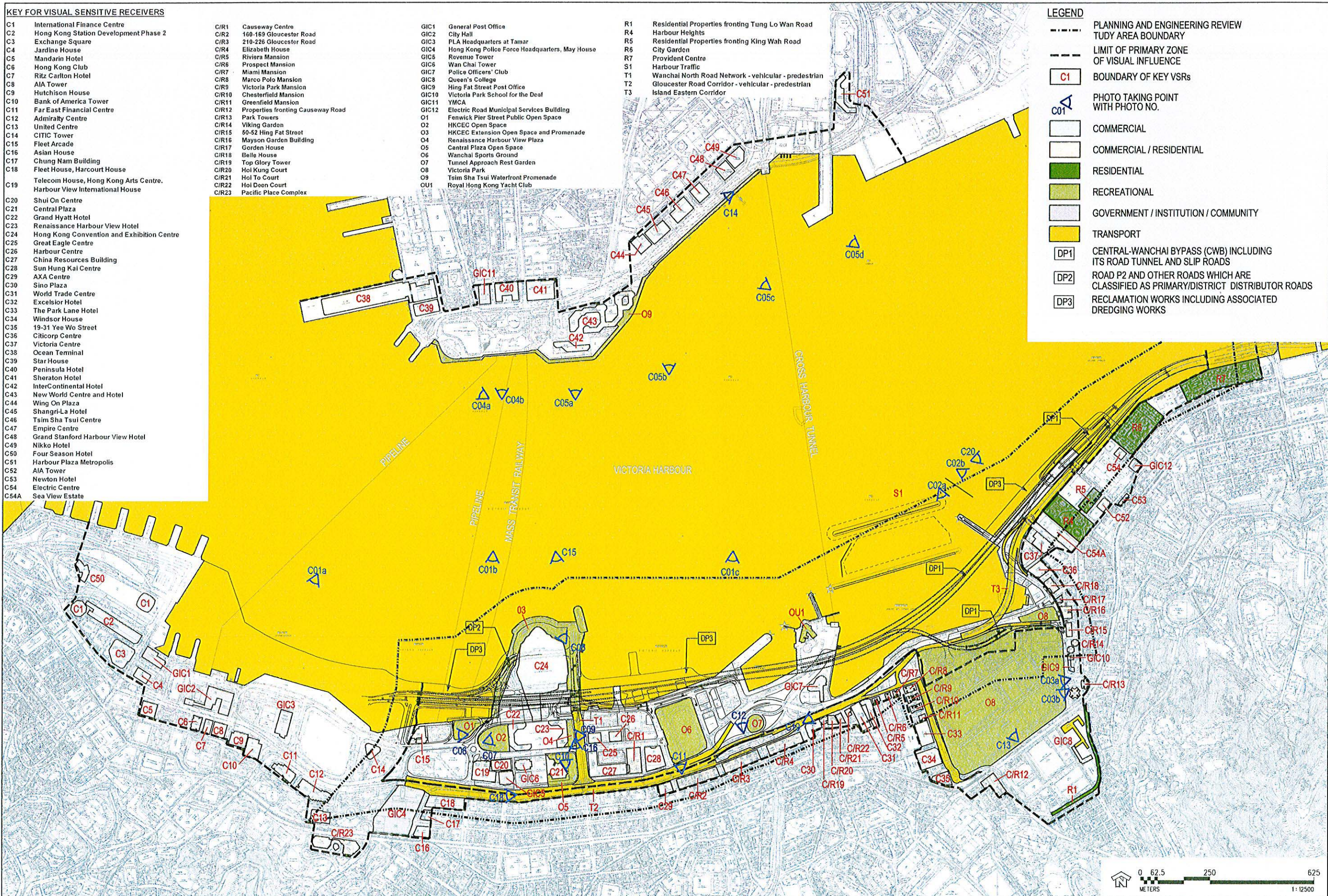

21/09/2007 16:02:32

FILE: \\wanchai\eg\chem\FIGURE 6-3.dgn

KEY FOR VSRs

- | | | | | |
|--|---|--|---|--|
| C1 International Finance Centre | C/R1 Causeway Centre | GIC8 Queen's College | OU1 Royal Hong Kong Yacht Club | S1 Harbour Traffic |
| C2 Hong Kong Station Development Phase 2 | C/R2 160-169 Gloucester Road | GIC9 Hing Fat Street Post Office | OU2 Planned Waterfront Related Commercial and Leisure Uses (CDE4) | T2 Wanchai North Road Network - vehicular - pedestrian |
| C3 Exchange Square | C/R3 210-226 Gloucester Road | GIC10 Victoria Park School for the Deaf | OU3 Planned Waterfront Related Commercial and Leisure Uses (CDE9) | T3 Gloucester Road Corridor - vehicular - pedestrian |
| C4 Jardine House | C/R4 Elizabeth House | GIC11 YMCA | OU4 Planned Waterfront Related Commercial and Leisure Use (East - WDI/13, WDI/14, WDI/17) | |
| C5 Mandarin Hotel | C/R5 Riviera Mansion | GIC12 Electric Road Municipal Services Building | R1 Residential Properties fronting Tung Lo Wan Road | |
| C6 Hong Kong Club | C/R6 Prospect Mansion | GIC13 Railway Station WDI/15, Harbour Road Sports Centre and Wan Chai Swimming Pool re-provisioned above the railway station | R4 Harbour Heights | |
| C7 Ritz Carlton Hotel | C/R7 Miami Mansion | | R5 Residential Properties fronting King Wah Road | |
| C8 AIA Tower | C/R8 Marco Polo Mansion | | R6 City Garden | |
| C9 Hutchison House | C/R9 Victoria Park Mansion | | R7 Provident Garden | |
| C10 Bank of America Tower | C/R10 Chesterfield Mansion | GIC14 Planned Hong Kong Academy of Performing Arts | | |
| C11 Far East Financial Centre | C/R11 Greenfield Mansion | GIC15 Planned Central Government Complex (CDE8) | | |
| C12 Admiralty Centre | C/R12 Properties fronting Causeway Road | GIC16 Planned Government Complex (CDE10) | | |
| C13 United Centre | C/R13 Park Towers | GIC17 Planned CDA Development (CDE3) | | |
| C14 CITIC Tower | C/R14 Viking Garden | O2 HKCEC Open Space | | |
| C15 Fleet Arcade | C/R15 50-52 Hing Fat Street | O3 HKCEC Extension Open Space and Promenade | | |
| C16 Asian House | C/R16 Mayson Garden Building | O4 Renaissance Harbour View Plaza | | |
| C17 Chung Nam Building | C/R17 Garden House | O5 Central Plaza Open Space | | |
| C18 Fleet House, Harcourt House | C/R18 Belle House | O6 Wanchai Sports Ground | | |
| C19 Telecom House, Hong Kong Arts Centre, Harbour View International House | C/R19 Top Glory Tower | O7 Tunnel Approach Rest Garden | | |
| C20 Shui On Centre | C/R20 Hoi Kung Court | O8 Victoria Park | | |
| C21 Central Plaza | C/R21 Hoi To Court | O9 Tsim Sha Tsui Waterfront Promenade | | |
| C22 Grand Hyatt Hotel | C/R22 Hoi Deen Court | O11 Planned Street Market with Outdoor Performance Area | | |
| C23 Renaissance Harbour View Hotel | C/R23 Pacific Place Complex | O12 Planned Waterfront Regional Open Space | | |
| C24 Hong Kong Convention and Exhibition Centre | C/R24 Planned CDA at North Point | O13 Planned Kiosks and Leisure Boat Landing Area | | |
| C25 Great Eagle Centre | C/R25 Planned CDA(1) at North Point | O14 Planned Water Sports Centre | | |
| C26 Harbour Centre | GIC2 City Hall | O15 Planned Boardwalk | | |
| C27 China Resources Building | GIC3 PLA Headquarters at Tamar | O16 Planned Harbour Education Centre | | |
| C28 Sun Hung Kai Centre | GIC4 Hong Kong Police Force Headquarters, May House | O17 Planned Local Open Space | | |
| C29 AXA Centre | GIC5 Revenue Tower | O18 Planned Waterfront Park | | |
| C30 Sino Plaza | GIC6 Wan Chai Tower | O19 Planned Regional Open Space (CDE2) | | |
| C31 World Trade Centre | GIC7 Police Officers' Club | | | |

- LEGEND**
- PLANNING AND ENGINEERING REVIEW STUDY AREA BOUNDARY
 - - - LIMIT OF PRIMARY ZONE OF VISUAL INFLUENCE
 - C1 BOUNDARY OF KEY VSRs
 - COMMERCIAL
 - COMMERCIAL / RESIDENTIAL
 - RESIDENTIAL
 - RECREATIONAL
 - GOVERNMENT / INSTITUTION / COMMUNITY
 - TRANSPORT
 - DP1 CENTRAL-WANCHAI BYPASS (CWB) INCLUDING ITS ROAD TUNNEL AND SLIP ROADS
 - DP2 ROAD P2 AND OTHER ROADS WHICH ARE CLASSIFIED AS PRIMARY/DISTRICT DISTRIBUTOR ROADS
 - DP3 RECLAMATION WORKS INCLUDING ASSOCIATED DREDGING WORKS

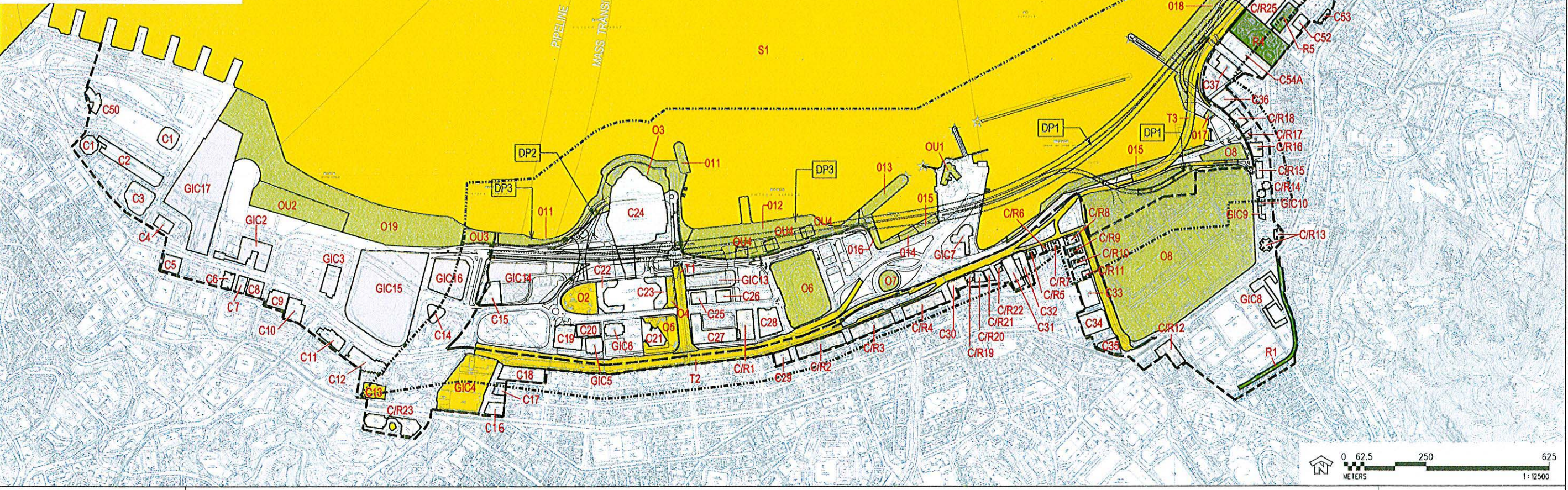

27/9/2007 16:03:44
FILE: \\wanchai\dgn\tem\FIGURE 6-3a.dgn

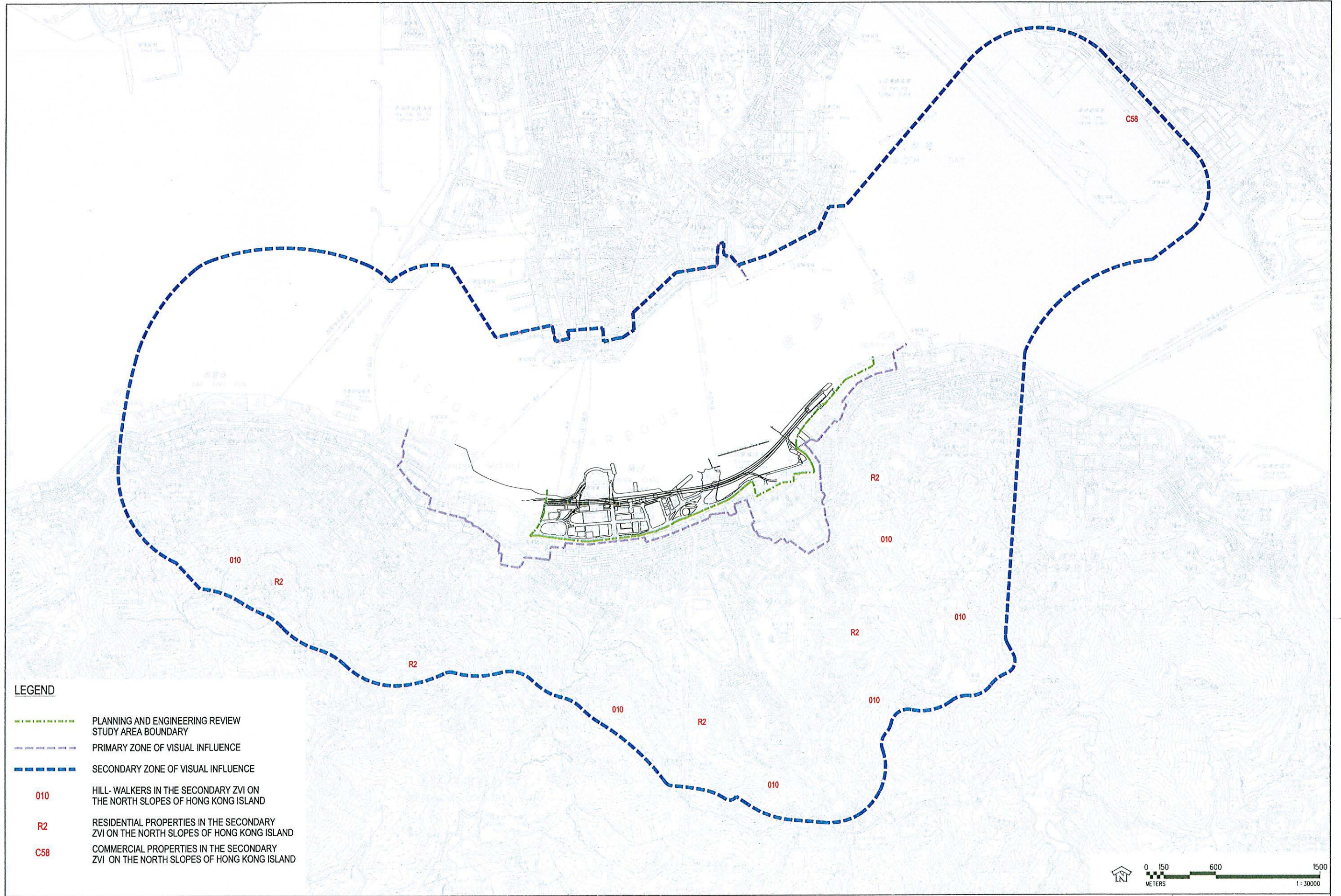

LEGEND

- - - - - PLANNING AND ENGINEERING REVIEW STUDY AREA BOUNDARY
- - - - - PRIMARY ZONE OF VISUAL INFLUENCE
- - - - - SECONDARY ZONE OF VISUAL INFLUENCE
- 010 HILL- WALKERS IN THE SECONDARY ZVI ON THE NORTH SLOPES OF HONG KONG ISLAND
- R2 RESIDENTIAL PROPERTIES IN THE SECONDARY ZVI ON THE NORTH SLOPES OF HONG KONG ISLAND
- C58 COMMERCIAL PROPERTIES IN THE SECONDARY ZVI ON THE NORTH SLOPES OF HONG KONG ISLAND

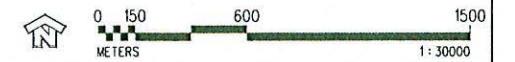

Appendix A

Implementation Schedule

IMPLEMENTATION SCHEDULE OF THE PROPOSED MITIGATION MEASURES

Table A.1 Implementation Schedule for Air Quality Control

WDII & CWB EIA Report Ref	Environmental Protection Measures / Mitigation Measures	Location / Timing	Implementation Agent	Implementation Stages*				Relevant Legislation and Guidelines
				Des	C	O	Dec	
Construction Phase								
S3.6.5	Four times a day watering of the work site with active operations.	Work site / during construction	Contractor		√			EIAO-TM
S3.8.1	Implementation of dust suppression measures stipulated in Air Pollution Control (Construction Dust) Regulation. The following mitigation measures, good site practices and a comprehensive dust monitoring and audit programme are recommended to minimise cumulative dust impacts. <ul style="list-style-type: none"> Strictly limit the truck speed on site to below 10 km per hour and water spraying to keep the haul roads in wet condition; Watering during excavation and material handling; Provision of vehicle wheel and body washing facilities at the exit points of the site, combined with cleaning of public roads where necessary; and Tarpaulin covering of all dusty vehicle loads transported to, from and between site locations. 	Work site / during construction	Contractor		√			
Operational Phase								
S3.6.53 – S3.6.54	The design parameters of the East and Central Ventilation Buildings as set in Tables 3.10 and 3.11 of Volume 1 of the WDII & CWB EIA Report.	East and Central Ventilation Buildings / During operation of the Trunk Road	HyD			√		
S3.10.2	Air quality monitoring for the operation performance of the East Ventilation Building and associated East Vent Shaft will be conducted.	East Vent Shaft / During operation of the East Ventilation Building and associated East Vent Shaft	HyD			√		EIAO-TM

* Des - Design, C - Construction, O – Operation, and Dec - Decommissioning

Table A.2 Implementation Schedule for Noise Control

WDII & CWB EIA Report Ref	Environmental Protection Measures / Mitigation Measures	Location / Timing	Implementation Agent	Implementation Stages*				Relevant Legislation and Guidelines
				Des	C	O	Dec	
Construction Phase								
S4.9.3	<p>Good Site Practice:</p> <ul style="list-style-type: none"> • Only well-maintained plant shall be operated on-site and plant shall be serviced regularly during the construction program. • Silencers or mufflers on construction equipment shall be utilized and shall be properly maintained during the construction program. • Mobile plant, if any, shall be sited as far away from NSRs as possible. • Machines and plant (such as trucks) that may be in intermittent use shall be shut down between works periods or shall be throttled down to a minimum. • Plant known to emit noise strongly in one direction shall, wherever possible, be orientated so that the noise is directed away from the nearby NSRs. • Material stockpiles and other structures shall be effectively utilized, wherever practicable, in screening noise from on-site construction activities. 	Work Sites / During Construction	Contractor		√			EIAO-TM, NCO
S4.8.1 – S4.8.11	<p>Use of quiet powered mechanical equipment, movable noise barrier and temporary noise barrier for the following tasks:</p> <ul style="list-style-type: none"> • Slip road 8 tunnel • Construction of diaphragm wall and substructures of the tunnel approach ramp • Excavation • Construction of slabs • Backfill 	Work Sites / During Construction	Contractor		√			EIAO-TM, NCO

WDII & CWB EIA Report Ref	Environmental Protection Measures / Mitigation Measures	Location / Timing	Implementation Agent	Implementation Stages*				Relevant Legislation and Guidelines
				Des	C	O	Dec	
	<ul style="list-style-type: none"> Demolition and construction of substructures for the IEC Demolition works of existing piers and crossheads of the marine section of the existing IEC <p>Use of PME grouping for the following tasks:</p> <ul style="list-style-type: none"> At-grade road construction Substructure for IECL connection 							
Operation Phase								
S4.8.12 – S4.8.23	<p>For Existing NSRs</p> <ul style="list-style-type: none"> about 235m length of noise semi-enclosure with transparent panel covering the westbound slip road from the IEC about 230m length of noise semi-enclosure with transparent panel covering the main carriageways (eastbound and westbound) of the CWB and IEC about 135m length of 5.5m high cantilevered noise barrier with 4.5m cantilever inclined at 45° with transparent panel on the eastbound slip road to the IEC (amended under EP-364/2009/A) about 95m length of 5.5m high cantilevered noise barrier with 1m cantilever inclined at 45° with transparent panel on the eastbound slip road to the IEC about 350m length of 3.5m high vertical noise barrier with transparent panel on the eastbound slip road to the IEC low noise road surfacing for the trunk road (except tunnel section and beneath the landscaped deck at the eastern portal area) with speed limit of 70 km/hour 	Near North Point / Before commencement of operation of road project	HyD	√	√	√		EIAO-TM

WDII & CWB EIA Report Ref	Environmental Protection Measures / Mitigation Measures	Location / Timing	Implementation Agent	Implementation Stages*				Relevant Legislation and Guidelines
				Des	C	O	Dec	
	For Future/Planned NSRs <ul style="list-style-type: none"> about 265m length of noise semi-enclosure with transparent panel covering the westbound slip road from the IEC The openable windows of the temple, if any, should be orientated so as to avoid direct line of sight to the existing Victoria Park Road as far as practicable. 	In between the Electric Centre (next to City Garden) and CDA(1) site / Before occupation of Planned NSRs in CDA and CDA(1) sites. Near Causeway Bay Fire Station / During detailed design of the re-provisioned Tin Hau Temple	HyD Project Proponent for the re-provisioned Tin Hau Temple	√	√ #			

* Des - Design, C - Construction, O – Operation, and Dec - Decommissioning

Only the steel frame for this section of noise semi-enclosure would be erected in advance during the construction of the westbound slip road.

Table A.3 Implementation Schedule for Water Quality Control

WDII & CWB EIA Report Ref	Environmental Protection Measures / Mitigation Measures	Location / Timing	Implementation Agent	Implementation Stages*				Relevant Legislation and Guidelines
				Des	C	O	Dec	
Construction Phase								
S5.8	<p><i>Construction Runoff and Drainage</i></p> <p>Exposed soil areas should be minimised to reduce the potential for increased siltation, contamination of runoff, and erosion. Construction runoff related impacts associated with the above ground construction activities can be readily controlled through the use of sediment traps and adequate maintenance of drainage systems to prevent flooding and overflow.</p> <p>Construction site should be provided with adequately designed perimeter channel and pre-treatment facilities and proper maintenance. The boundaries of critical areas of earthworks should be marked and surrounded by dykes or embankments for flood protection. Temporary ditches should be provided to facilitate runoff discharge into the appropriate watercourses, via a silt retention pond. Permanent drainage channels should incorporate sediment basins or traps and baffles to enhance deposition rates. The design of efficient silt removal facilities should be based on the guidelines in Appendix A1 of ProPECC PN 1/94.</p> <p>Ideally, construction works should be programmed to minimise surface excavation works during the rainy season (April to September). All exposed earth areas should be completed as soon as possible after earthworks have been completed, or alternatively, within 14 days of the cessation of earthworks where practicable. If excavation of soil cannot be avoided during the rainy season, or at any time of year when rainstorms are likely, exposed slope surfaces should be covered by tarpaulin or other means.</p> <p>A sediment tank constructed from pre-formed individual cells of approximately 6 - 8 m³ capacity can be used for settling ground water prior to disposal;</p> <p>Open stockpiles of construction materials (for examples, aggregates, sand and fill material) of more than 50 m³ should be covered with tarpaulin or similar fabric during rainstorms. Measures should be taken to prevent the washing away of construction materials, soil, silt or debris into any drainage system.</p>	Work site / During the construction period	Contractor		√			ProPECC PN 1/94; WPCO (TM-DSS)

WDII & CWB EIA Report Ref	Environmental Protection Measures / Mitigation Measures	Location / Timing	Implementation Agent	Implementation Stages*				Relevant Legislation and Guidelines
				Des	C	O	Dec	
S5.8	<p>Manholes (including newly constructed ones) should always be adequately covered and temporarily sealed so as to prevent silt, construction materials or debris being washed into the drainage system and storm runoff being directed into foul sewers.</p> <p>Precautions to be taken at any time of year when rainstorms are likely, actions to be taken when a rainstorm is imminent or forecast, and actions to be taken during or after rainstorms are summarised in Appendix A2 of ProPECC PN 1/94. Particular attention should be paid to the control of silty surface runoff during storm events.</p> <p>Oil interceptors should be provided in the drainage system and regularly cleaned to prevent the release of oils and grease into the storm water drainage system after accidental spillages. The interceptor should have a bypass to prevent flushing during periods of heavy rain.</p> <p>All vehicles and plant should be cleaned before leaving a construction site to ensure no earth, mud, debris and the like is deposited by them on roads. An adequately designed and located wheel washing bay should be provided at every site exit, and wash-water should have sand and silt settled out and removed at least on a weekly basis to ensure the continued efficiency of the process. The section of access road leading to, and exiting from, the wheel-wash bay to the public road should be paved with sufficient backfall toward the wheel-wash bay to prevent vehicle tracking of soil and silty water to public roads and drains.</p>	Work site / During the construction period	Contractor		√			ProPECC PN 1/94; WPCO (TM-DSS)
S5.8	<p>It is recommended that on-site drainage system should be installed prior to the commencement of other construction activities. Sediment traps should be installed in order to minimise the sediment loading of the effluent prior to discharge into foul sewers. There shall be no direct discharge of effluent from the site into the sea.</p> <p>All temporary and permanent drainage pipes and culverts provided to facilitate runoff discharge shall be adequately designed for the controlled release of storm flows. All sediment control measures shall be regularly inspected and maintained to ensure proper and efficient operation at all times and particularly following rain storms. The temporarily diverted drainage shall be reinstated to its original condition when the construction work is finished or the temporary diversion is no longer required.</p>	Work site / During the construction period	Contractor		√			ProPECC PN 1/94; WPCO (TM-DSS)

WDII & CWB EIA Report Ref	Environmental Protection Measures / Mitigation Measures	Location / Timing	Implementation Agent	Implementation Stages*				Relevant Legislation and Guidelines
				Des	C	O	Dec	
S5.8	<p>All fuel tanks and store areas shall be provided with locks and be sited on sealed areas, within bunds of a capacity equal to 110% of the storage capacity.</p> <p><i>Sewage from Construction Work Force</i></p> <p>Construction work force sewage discharges on site shall be connected to the existing trunk sewer or sewage treatment facilities. The construction sewage shall be handled by portable chemical toilets prior to the commission of the on-site sewer system. Appropriate numbers of portable toilets shall be provided by a licensed contractor to serve the large number of construction workers over the construction site. The Contractor shall also be responsible for waste disposal and maintenance practices.</p>	Work site / During the construction period	Contractor		√			ProPECC PN 1/94; WPCO (TM-DSS)
S5.8	<p><i>Floating Debris and Refuse</i></p> <p>Collection and removal of floating refuse shall be performed at regular intervals on a daily basis. The contractor shall be responsible for keeping the water within the site boundary and the neighbouring water free from rubbish.</p>	Work site and adjacent water / During the construction period.	Contractor		√			WPCO
S5.8	<p><i>Storm Water Discharges</i></p> <p>Minimum distances of 100 m shall be maintained between the existing or planned stormwater discharges and the existing or planned WSD flushing water intakes.</p>	Work site and adjacent water / During the design and construction period.	Contractor	√	√			WPCO
Operation Phase								
S5.8	For the operation of CWB, a surface water drainage system would be provided to collect road runoff. The following operation stage mitigation measures are recommended to ensure road runoff would comply with the TM under the WPCO:	CWB/During design and operational period	HyD/TD ³	√		√		WPCO

WDII & CWB EIA Report Ref	Environmental Protection Measures / Mitigation Measures	Location / Timing	Implementation Agent	Implementation Stages*				Relevant Legislation and Guidelines
				Des	C	O	Dec	
	<ul style="list-style-type: none"> The drainage from tunnel sections shall be directed through petrol interceptors to remove oil and grease before being discharged to the nearby foul water manholes. Petrol interceptors shall be regularly cleaned and maintained in good working condition. 							
	<ul style="list-style-type: none"> Oily contents of the petrol interceptors shall be properly handled and disposed of, in compliance with the requirements of the Waste Disposal Ordinance. Sewage arising from ancillary facilities of CWB (for examples, car park, control room, ventilation and administration buildings and tunnel portals) shall be connected to public sewerage system. Sufficient capacity in public sewerage shall be made available to the proposed facilities. Road drainage shall also be provided with adequately designed silt trap to minimize discharge of silty runoff. The design of the operational stage mitigation measures for CWB shall take into account the guidelines published in ProPECC PN 5/93 "Drainage Plans subject to Comment by the EPD." All operational discharges from the CWB into drainage or sewerage systems are required to be licensed by EPD under the WPCO. 							

* Des - Design, C - Construction, O – Operation, and Dec - Decommissioning

³ if employ Management, Operation and Maintenance (MOM) Contract

Table A.4 Implementation Schedule for Waste Management

WDII & CWB EIA Report Ref	Environmental Protection Measures / Mitigation Measures	Location / Timing	Implementation Agent	Implementation Stages*				Relevant Legislation and Guidelines
				Des	C	O	Dec	
Construction Phase								
S6.5.14	<i>Floating Refuse</i> During the construction phase, the project proponent's contractor will be responsible for the collection of any refuse within their works area.	Work site / During the construction period	Contractor		√			
S6.6.1	<i>Good Site Practices</i> Recommendations for good site practices during the construction activities include: <ul style="list-style-type: none"> • nomination of an approved person, such as a site manager, to be responsible for good site practices, arrangements for collection and effective disposal to an appropriate facility, of all wastes generated at the site; • training of site personnel in proper waste management and chemical waste handling procedures; • provision of sufficient waste disposal points and regular collection for disposal; • appropriate measures to minimise windblown litter and dust during transportation of waste by either covering trucks or by transporting wastes in enclosed containers; • regular cleaning and maintenance programme for drainage systems, sumps and oil interceptors; and • a recording system for the amount of wastes generated, recycled and disposed of (including the disposal sites). 	Work site / During the construction period	Contractor		√			Waste Disposal Ordinance (Cap.354)

WDII & CWB EIA Report Ref	Environmental Protection Measures / Mitigation Measures	Location / Timing	Implementation Agent	Implementation Stages*				Relevant Legislation and Guidelines
				Des	C	O	Dec	
S6.6.2	<p><i>Waste Reduction Measures</i></p> <p>Waste reduction is best achieved at the planning and design stage, as well as by ensuring the implementation of good site practices. Recommendations to achieve waste reduction include:</p> <ul style="list-style-type: none"> • segregation and storage of different types of waste in different containers, skips or stockpiles to enhance reuse or recycling of materials and their proper disposal; • to encourage collection of aluminium cans, PET bottles and paper, separate labelled bins shall be provided to segregate these wastes from other general refuse generated by the work force; • any unused chemicals or those with remaining functional capacity shall be recycled; • use of reusable non-timber formwork, such as in casting the tunnel box sections, to reduce the amount of C&D material. • prior to disposal of C&D waste, it is recommended that wood, steel and other metals shall be separated for re-use and / or recycling to minimise the quantity of waste to be disposed of to landfill; • proper storage and site practices to minimise the potential for damage or contamination of construction materials; and • plan and stock construction materials carefully to minimise amount of waste generated and avoid unnecessary generation of waste. 	Work site / During planning and design stage, and construction stage	Contractor	√	√			

WDII & CWB EIA Report Ref	Environmental Protection Measures / Mitigation Measures	Location / Timing	Implementation Agent	Implementation Stages*				Relevant Legislation and Guidelines
				Des	C	O	Dec	
S6.6.4	<p><i>General Refuse</i></p> <p>General refuse shall be stored in enclosed bins or compaction units separate from C&D material. A licensed waste collector shall be employed by the contractor to remove general refuse from the site, separately from C&D material.</p> <p>A collection area shall be provided where wastes can be stored and loaded prior to removal from site. An enclosed and covered area is recommended to reduce the occurrence of 'wind blow' light material.</p>	Work site / During the construction period	Contractor		√			Public Health and Municipal Services Ordinance (Cap. 132)
S6.6.5	<p><i>Chemical Wastes</i></p> <p>After use, chemical wastes (for example, cleaning fluids, solvents, lubrication oil and fuel) shall be handled according to the Code of Practice on the Packaging, Labelling and Storage of Chemical Wastes. Spent chemicals shall be collected by a licensed collector for disposal at the CWTF or other licensed facility in accordance with the Waste Disposal (Chemical Waste) (General) Regulation.</p>	Work site / During the construction period	Contractor		√			<p>Waste Disposal (Chemical Waste) (General) Regulation</p> <p>Code of Practice on the Packaging, Labelling and Storage of Chemical Wastes</p>
S6.6.6	<p><i>Construction and Demolition Material</i></p> <p>C&D material shall be sorted on-site into inert C&D material (that is, public fill) and C&D waste. All the suitable inert C&D material shall be broken down to 250 mm in size for reuse as public fill in the WDII reclamation. C&D waste, such as wood, glass, plastic, steel and other metals shall be reused or recycled and, as a last resort, disposed of to landfill. A suitable area shall be designated to facilitate the sorting process and a temporary stockpiling area will be required for the separated materials.</p>	Work site / During the construction period	Contractor		√			ETWB TCW No. 33/2002, 31/2004, 19/2005

WDII & CWB EIA Report Ref	Environmental Protection Measures / Mitigation Measures	Location / Timing	Implementation Agent	Implementation Stages*				Relevant Legislation and Guidelines
				Des	C	O	Dec	
S6.6.7	In order to monitor the disposal of public fill and C&D waste at public fill reception facilities and landfills, respectively, and to control fly tipping, a trip-ticket system shall be included as one of the contractual requirements and implemented by the Environmental Team undertaking the environmental monitoring and audit work. The Independent Environment Checker shall be responsible for auditing the results of the system.	Work site / During the construction period	Contractor and Independent Environmental Checker		√			ETWB TCW No. 31/2004
S6.6.8	<p><i>Bentonite Slurry</i></p> <p>The disposal of residual used bentonite slurry shall follow the good practice guidelines stated in ProPECC PN 1/94 “Construction Site Drainage” and listed as follows:</p> <ul style="list-style-type: none"> • If the disposal of a certain residual quantity cannot be avoided, the used slurry may be disposed of at the marine spoil grounds subject to obtaining a marine dumping licence from EPD on a case-by-case basis. • If the used bentonite slurry is intended to be disposed of through the public drainage system, it shall be treated to the respective effluent standards applicable to foul sewers, storm drains or the receiving waters as set out in the Technical Memorandum of Standards for Effluents Discharged into Drainage and Sewerage Systems, Inland and Coastal Waters. • If the used bentonite slurry is intended to be disposed to public fill reception facilities, it will be mixed with dry soil on site before disposal. 	Work site / During the construction period	Contractor		√			ProPECC PN 1/94

* Des - Design, C - Construction, O – Operation, and Dec - Decommissioning

Table A.5 Implementation Schedule for Land Contamination

WDII & CWB EIA Report Ref	Environmental Protection Measures / Mitigation Measures	Location / Timing	Implementation Agent	Implementation Stages*				Relevant Legislation and Guidelines
				Des	C	O	Dec	
Construction and Operation Phase								
S.7.1.1	As no potential contaminative land uses were identified within the Study Area, adverse land contamination impacts associated with the construction and operation of the Project is not expected. As such, environmental protection and mitigation measures are considered not necessary and will not be covered in this EM&A Manual.	-	-					-

* Des - Design, C - Construction, O – Operation, and Dec - Decommissioning

Table A.6 Implementation Schedule for Marine Ecology

WDII & CWB EIA Report Ref	Environmental Protection Measures / Mitigation Measures	Location / Timing	Implementation Agent	Implementation Stages*				Relevant Legislation and Guidelines
				Des	C	O	Dec	
Construction & Operation Phases								
S.9.7.1	As no adverse ecological impact on marine habitats and associated wildlife is identified, no necessary mitigation measure is considered as required in this assessment. The mitigation measures recommended in the water quality impact assessment to control water quality would also serve to protect marine ecological resources from indirect impacts and ensure no adverse impact on marine life would be resulted from this designated project. Hence EM&A for marine ecology will not be covered in this EM&A Manual.	-	-					-

*Des - Design, C - Construction, O – Operation, and Dec - Decommissioning

Table A.7 Implementation Schedule for Landscape and Visual

WDII & CWB EIA Report Ref	Environmental Protection Measures / Mitigation Measures	Location / Timing	Implementation Agent	Implementation Stages*				Relevant Legislation and Guidelines
				Des	C	O	Dec	
Construction Phase								
Table 10.5	CM1 Topsoil, where identified, shall be stripped and stored for re-use in the construction of the soft landscape works, where practical.	Work site / During Construction Phase	Contractor	√	√			EIAO TM
Table 10.5	CM2 Existing trees to be retained on site shall be carefully protected during construction.	Work site / During Construction Phase	Contractor	√	√			EIAO TM
Table 10.5	CM3 Trees unavoidably affected by the works shall be transplanted where practical.	Work site / During Construction Phase	Contractor	√	√			EIAO TM
Table 10.5	CM4 Compensatory tree planting shall be provided to compensate for felled trees.	Work site / During Construction Phase	Contractor	√	√			EIAO TM
Table 10.5	CM5 Control of night-time lighting.	Work site / During Construction Phase	Contractor		√			EIAO TM
Table 10.5	CM6 Erection of decorative screen hoarding compatible with the surrounding setting.	Work site / During Construction Phase	Contractor		√			EIAO TM
Operation Phase								
Table 10.6, Figure 10.5.1-10.5.5	OM1 Aesthetic design of buildings and road-related structures, including viaducts, vent buildings, subways, footbridges and noise barriers and enclosure.	Work site / During Design Stage and Operation Phases	HyD	√	√	√		ETWB TCW 2/2004
Table 10.6, Figure 10.5.1-10.5.5	OM3 Buffer Tree and Shrub Planting to screen proposed roads and associated structures.	Work site / During Design Stage and Operation Phases	HyD	√	√	√		ETWB TCW 2/2004
Table 10.6, Figure 10.5.1-10.5.5	OM5 Aesthetic streetscape design.	Work site / During Design Stage and Operation Phases	HyD	√	√	√		ETWB TCW 2/2004
Table 10.6, Figure 10.5.1-10.5.5	OM6 Aesthetic design of roadside amenity areas.	Work site / During Design Stage and Operation Phases	HyD	√	√	√		ETWB TCW 2/2004

*Des - Design, C - Construction, O – Operation, and Dec - Decommissioning

Appendix B
Sample Data Sheet for Air Quality
And Noise Monitoring

APPENDIX B1 Data Record Sheet for TSP Monitoring

Monitoring Location		
Details of Location		
Sampler Identification		
Date & Time of Sampling		
Elapsed-time	Start (min.)	
Meter Reading	Stop (min.)	
Total Sampling Time (min.)		
Weather Conditions		Sunny / Fine / Cloudy / Rainy
Site Conditions		
Initial Flow Rate, Qsi	Pi (mmHg)	
	Ti (°C)	
	Hi (in.)	
	Qsi (Std. m ³)	
Final Flow Rate, Qsf	Pf (mmHg)	
	Tf (°C)	
	Hf (in.)	
	Qsf (Std. m ³)	
Average Flow Rate (Std. m ³)		
Total Volume (Std. m ³)		
Filter Paper Identification No.		
Initial Wt. of Filter Paper (g)		
Final Wt. of Filter Paper (g)		
Measured TSP Level (µg/m ³)		
Other Dust Emission Source(s) Observed		
Remarks /Other Observations		

Name & Designation

Signature

Date

Field Operator:

Laboratory Staff:

Checked by:

APPENDIX B2 Construction Noise Monitoring Field Record Sheet

Monitoring Location		
Description of Location		
Date of Monitoring		
Measurement Start Time	(hh:mm)	
Measurement Time Length	(min.)	
Noise Meter Model/Identification		
Calibrator Model/Identification		
Measurement Results	L ₉₀ (dB(A))	
	L ₁₀ (dB(A))	
	L _{eq} (dB(A))	
Major Construction Noise Source(s) During Monitoring		
Other Noise Source(s) During Monitoring		
Remarks / Other Observations		

Name & Designation

Signature

Date

Recorded by:

Checked by:

Appendix C
Sample Template for the
Interim Notification

Appendix C Sample Template for the Interim Notification

Incident Report on Action Level or Limit Level Exceedance

Project	
Date	
Time	
Monitoring Location	
Parameter	
Action & Limit Levels	
Measured Level	
Possible reason for Action or Limit Level Non-compliance	
Actions taken / to be taken	
Remarks / Other Observations	

Prepared by: _____

Designation: _____

Signature: _____

Date: _____

Appendix D
Operation Stage
Traffic Noise Monitoring –
Field Survey Record Sheet

APPENDIX D Operational Stage Traffic Noise Monitoring – Field Survey Record Sheet

General

Monitoring Location/Reference No.	
Person-in-charge	
Date and Day of Monitoring	
Measurement Time	From to
Description of Location (incl. Floor level) (attach plan separately)	
Microphone Position	

Weather Conditions

Weather Conditions.	
Temperature (°C)	
Wind Speed (ms ⁻¹)	

Equipment

Instrument.	Type	Serial No.	Setting
Sound Level Meter			
Calibration			

Calibration

Before Measurement:	After Measurement:
---------------------	--------------------

Raw Data

Time	Traffic data*				Noise Level (30 min) dB(A)				Average Speed kph a/b c/d #
	Near Side		Far Side		L ₁₀	L ₉₀	L _{eq}	L _{max}	
	LV	HV	LV	HV					

Note: LV - light vehicle (i.e. private car, motorcycle, taxis and van)
 HV - heavy vehicle (i.e. other than LV)
 * - traffic count for a duration of 15 minutes
 # - a/b | c/d = near side LV/near side HV | far side LV/far side HV

**APPENDIX D Operational Stage Traffic Noise Monitoring – Field Survey Record Sheet
(cont'd)**

Others

Mitigation Measures in Place Near Measurement Location	
Other Noise source(s) during monitoring	
Remarks	

Personnel

	Name	Designation	Signature	Date
Recorded by				
Checked by				

Appendix E
Terms of Reference and Details
for the ENPC and CLG

(version 1.5)

Environmental Project Committee (ENPC) set up under Environmental Permits No. EP-356/2009, No. EP-364/2009 and EP-376/2009

1. Aim of ENPC
 - 1.1 The Condition 2.3 of the Environmental Permit No. EP-356/2009 stipulates that to oversee and facilitate effective control of the cumulative environmental impacts arising from potential multiple contracts for the construction of the entire Wan Chai Development Phase II (WDII) and Central-Wanchai Bypass (CWB) (hereafter referred to as the whole Project), the Permit Holder shall set up an Environmental Project Committee (ENPC) before the commencement of construction of the earliest components of the whole Project.
 - 1.2 The Condition 2.3 of the Environmental Permit No. EP-364/2009 also stipulates that to oversee and facilitate effective control of the cumulative environmental impacts arising from potential multiple contracts for the construction of the entire Wan Chai Development Phase II (WDII) and Central-Wanchai Bypass (CWB) (hereafter referred to as the whole Project), the Permit Holder shall liaise with the permit holder of environmental permit No. EP-356/2009 to jointly set up an Environmental Project Committee (ENPC). The ENPC shall be set up before the commencement of construction of the earliest components of the whole Project.
 - 1.3 The Condition 2.3 of the Environmental Permit No. EP-376/2009 also stipulates that to oversee and facilitate effective control of the cumulative environmental impacts arising from potential multiple contracts for the construction of the entire Wan Chai Development Phase II (WDII) and Central-Wan Chai Bypass (CWB) (hereafter referred to as the whole Project), the Permit Holder shall liaise with the permit holder of environmental permit No. EP-356/2009 and the permit holder of environmental permit No. EP-364/2009 to jointly set up an Environmental Project Committee (ENPC). The ENPC shall be set up before the commencement of construction of the earliest components of the whole Project.
 - 1.4 Hence the ENPC is set up to specifically meet the requirements in the Condition 2.3 of the Environmental Permits No. EP-356/2009, No. EP-364/2009 and No. EP-376/2009 (the EPs).
2. Terms of Reference
 - 2.1 The ENPC is set up to oversee and facilitate effective control of the cumulative environmental impacts arising from potential multiple contracts for the construction of the entire Wan Chai Development Phase II (WDII) and Central-Wan Chai Bypass (CWB) (hereafter referred to as the whole Project).
 - 2.2 Specifically the ENPC will :
 - (a) review regularly the cumulative environmental impacts arising from the works contracts for the construction of the whole Project;
 - (b) review the environmental performance of individual works contracts under the whole Project;

(version 1.5)

- (c) coordinate the actions of the parties concerned for improving the environmental performance of the works contracts under the whole Project in order to ensure compliance of the environmental permits conditions and the relevant legislations;
- (d) discuss any necessary liaison works to be conducted by the Community Liaison Groups (CLGs) set up under the EPs to address potential cumulative environmental impact issues arising from the whole Project;
- (e) coordinate the actions in respect of handling and resolving environmental complaints and issues raised in the CLGs;
- (f) communicate with Environmental Protection Department in respect of the ENPC; and
- (g) make recommendations and update under the relevant condition of the Permits on how to enhance the monitoring and audit of the environmental performance of the whole Project on top of requirements as set out in the Permit Conditions or corresponding requirements set out under subsequent Environmental Permits issued for the whole Project.

3. Membership

- Chair** : The ENPC will be co-chaired by Civil Engineering and Development Department (Permit Holder of Environmental Permits No. EP-356/2009 and No. EP-376/2009) and Highways Department (Permit Holder of Environmental Permit No. EP-364/2009).
- Members** :
- (a) Engineer of the WDII project (WDII consultants).
 - (b) Engineer of the CWB project (CWB consultants).
 - (c) Engineer's Representative of the WDII works contracts.
 - (d) Engineer's Representative of the CWB works contracts.
 - (e) the Environmental Team (ET) Leader.
 - (f) the Independent Environmental Checker (IEC).
 - (g) the permit holders of the further EPs of the whole Project.
 - (h) the contractors of works contracts under the whole Project.
 - (i) representative of respective CLGs (representative to be appointed by CLGs).
- Secretaries** : RE/Environmental for the WDII works contracts and RE/Environmental for the CWB works contracts.

(version 1.5)

4. Operation of ENPC

4.1 ENPC Meetings

- (a) The ENPC will meet on monthly basis, or as required by the activities of the whole Project, or as requested by the ENPC. However, the frequency of the ENPC Meetings will be reconsidered when the majority of the works contracts under the whole Project are completed.
- (b) CEDD and HyD will chair the ENPC meeting alternatively.
- (c) The dates of the meetings will be determined at the ENPC meetings. Normally the monthly meetings will be held following the submission of the monthly EM&A Reports by the ET Leader to ensure that the most up to date information in respect of EM&A can be discussed at the meetings.
- (d) The ENPC Secretaries will take up the secretarial works for the ENPC meeting.
- (e) The secretaries will prepare the proposed meeting agenda and circulate it to members for comments prior to each ENPC meeting. The meeting agenda will contain the following major items :
 - Report on matters related to the EM&A by the ET Leader and the IEC.
 - Issues related to the CLG.
 - Specific environmental issues raised.
 - Review of actions from the previous meeting.

4.2 Communications

External communications of the ENPC shall be through the Chair.

5. Responsibilities

The ENPC is only to coordinate the actions by the respective parties to oversee and facilitate effective control of the cumulative environmental impacts arising from the multiple contracts for the construction of the whole Project. The decisions made or the actions agreed at the ENPC should not be considered as constituting instructions under individual works contracts of the whole Project. The Employers, the Engineers, the Engineer's Representatives, the ET Leader, and the IEC for individual works contracts shall carry out their own necessary contract administrative procedures for implementing the actions as agreed at the ENPC.

(version 1.7)

Community Liaison Groups (CLG) Set Up under Environmental Permits No. EP-356/2009, No. EP-364/2009 and EP-376/2009

1. Aim of CLG

- 1.1 Condition 2.4 of the Environmental Permits No. EP-356/2009, No. EP-364/2009 and No. EP-376/2009 (the EPs) stipulates that the Permit Holders shall set up a Community Liaison Group (CLG) comprising representatives from the relevant concerned and affected parties, including owners' corporations, management offices, local committees and schools of affected areas, including the North Point and Tin Hau areas, to facilitate communication, enquiries and complaints handling on all environmental issues, including the follow up on the implementation of remedial mitigation measures. The Permit Holders shall set up the CLG before the commencement of construction of the relevant component(s) of the WDII and CWB Project. A designated complaint hotline shall also be set up for the Project to address such concerns and complaints in an efficient manner. The detailed arrangements of the CLG shall be reported to the Environmental Project Committee (ENPC) and its activities be reflected as update in the EM&A Manuals for the Project.
- 1.2 Hence the CLG is set up to specifically meet the above requirements in Condition 2.4 of the EPs.

2. Terms of Reference

- 2.1 The role of CLG is consultative. It is set up to facilitate communication, enquiries and complaints handling on all environmental issues including the follow up on the implementation of remedial mitigation measures.
- 2.2 Specifically the CLG will meet regularly :
- (a) to provide a platform for the Permit Holders to communicate with the public to understand the construction activities of the Project and the associated environmental issues to the community;
 - (b) to review the environmental concerns and complaints received from the public and to report any exceedence of limits observed; and
 - (c) to review the follow-up on the implementation of remedial mitigation measures.

3. Setting-up CLGs

- 3.1 As the stakeholders for different parts of the project area are different, separate CLG will be formed for different areas to facilitate effective and efficient communication with the community. The following four CLGs will be formed :
- (a) North Point CLG for Highways Department's works contracts at North Point and covering the community of the North Point and Tin Hau areas.
 - (b) Causeway Bay CLG for Highways Department's works contracts at Causeway Bay and covering the community of the Causeway Bay area.
 - (c) Wan Chai CLG for Civil Engineering and Development Department's works contracts at

Wan Chai and covering the community of the Wan Chai area.

(version 1.7)

- (d) Central CLG for Highways Department's works contracts at Central and covering the community of the Central area.

The extent of the community to be invited to join each of the above CLGs will be determined by the relevant EP Holders and the Engineer's Representatives, taking into account the likely extents of the environmental impacts and the public liaison requirements.

4. Membership

- 4.1 Chair : The CLG will be chaired by the Engineer's Representatives of the CWB and WDII works contracts. (If there are more than one works contracts and hence more than one Engineer's Representatives, only one Engineer's Representative is to be assigned to chair one CLG.)
- 4.2 Members :
- (a) Engineer's Representatives for the works contracts.
 - (b) Environmental Team (ET) Leader.
 - (c) Independent Environmental Checker (IEC).
 - (d) representative from the relevant EP Holders and FEP Holders (including the persons responsible for public relation issues from the works contractors)
 - (e) the environmental consultants of WDII project and CWB project
 - (f) Representatives from District Offices will be invited to attend on as-needed basis.
 - (g) representatives from concerned stakeholders of the relevant community (as listed in Appendix A).
- 4.3 Secretaries : RE/Environmental (or RE/Public Liaison) for the works contracts.

*(version 1.7)***5. Operation of CLG****5.1 CLG Meetings**

- (a) The CLG will meet as required by the activities of the Project or by the request of the Chair.
- (b) Meeting notes will be taken and distributed by the CLG Secretaries.
- (c) The secretaries will prepare the proposed meeting agenda with agreement of the Chair prior to each CLG meeting. The meeting agenda will contain the following major items :
 - Updates on the Project and construction activities.
 - Specific environmental issues raised.
 - Review of the implementation of remedial mitigation measures.
 - Review of actions from the previous meeting.
- (d) The detailed arrangements of CLG shall be reported to ENPC.

(version 1.7)

Appendix A

Remarks:

1. The Owner's Corporations are deemed to be represented by their appointed management offices. If the Owner's Corporation prefers to be member of the CLG, it will replace the corresponding management office as the CLG member.
2. The lists below are to be updated in the course of the relevant works.

A. North Point CLG members from the community of the North Point and Tin Hau areas

Item	The Community	Address and Contact Telephone Number	Contact Person
1.	PLK Yu Lee Mo Fan Memorial school	19 Wharf Road, North Point, Hong Kong Tel :2566 3805	To be confirmed
2.	Hong Kong Baptist Church Henrietta Secondary School	2 City Garden Road, North Point, Hong Kong Tel :25701466	Mr. Dai
3.	Management Office of City Garden	9 City Garden Road, North Point, Hong Kong Tel :270 4584	Mr. Chin
4.	Harbour Grand Hong Kong	23 Oil Street, North Point, Hong Kong Tel :2121 2688	To be confirmed
5.	Management Office of Fu Lee Loy Mansion	9-27 King Wah Road, North Point, Hong Kong	To be confirmed
6.	Wan Wah Mansion	11-13 Oil Street, North Point, Hong kong	To be confirmed
7.	Wang Fa Mansion	2 Wang On Road, North Point, Hong Kong	To be confirmed
8.	Victor Court	14-28 Wang On Rd, North Point, Hong Kong	To be confirmed
9.	Causeway Bay Community Centre	7 Fook Yum Road, North Point, Hong Kong Tel :3104 2303	Ms. Emily Cheng
10.	Management Office of Harbour Heights	3 Fook Yum Road, North Point, Hong Kong	To be confirmed

(version 1.7)

Item	The Community	Address and Contact Telephone Number	Contact Person
11.	Management Office of Sea View Estate	29-41 Tong Chong Street Quarry Bay, Hong Kong	To be confirmed
12.	Management Office of Victoria Centre	15 Watson Road, Causeway Bay, Hong Kong	To be confirmed
13.	Management Office of Hoi Tao Building	3 King Ming Road, Causeway Bay, Hong Kong	To be confirmed
14.	Kam Tao Building	4 Whitfield Road, Causeway Bay, Hong Kong	To be confirmed
15.	Ngan Tao Building	8 Whitfield Road, Causeway Bay, Hong Kong	To be confirmed
16.	Management Office of Citicorp Centre	18 Whitfield Road, Causeway Bay, Hong Kong	To be confirmed
17.	Management Offices of Belle House	98 Hing Fat Street, Causeway Bay, Hong Kong	To be confirmed
18.	Whitfield Mansion	15-19 Whitfield Road, Causeway Bay, Hong Kong	To be confirmed
19.	Shun Hing Building	11-13 Whitfield Road, Causeway Bay	To be confirmed
20.	Hoi Sing Building	128-142 2nd Street, Sai Ying Pun – located at Kenny Town, to be further checked	To be confirmed
21.	Ming Hing Building	9-11 Gordon Road, Causeway Bay, Hong Kong	To be confirmed
22.	Management Office of Gordon House	62-86 Hing Fat Street Causeway Bay, Hong Kong	To be confirmed

(version 1.7)

Item	The Community	Address and Contact Telephone Number	Contact Person
23.	Management Office of Mayson Garden Building	1A-1B Tsing Fung Street, Causeway Bay, Hong Kong	To be confirmed
24.	Management Office Victoria Court	2A Tsing Fung Street, Causeway Bay, Hong Kong or 50-56 Hing Fat Street, Causeway Bay Hong Kong	To be confirmed
25.	Management Office of Viking Garden	40 Hing Fat Street, Causeway Bay, Hong Kong	To be confirmed
26.	Victoria Park School for the Deaf	36 Hing Fat Street, Causeway Bay, Hong Kong	To be confirmed
27.	Management Office of Park Towers	1 King's Road, Causeway Bay, Hong Kong	To be confirmed
28.	Operations Branch of Water Supplies Department	WSD Hong Kong Regional Building, 611 King's Road, North Point, Hong Kong	To be confirmed
29.	Harbour Grand Hong Kong	23 Oil Street, North Point, Hong Kong	To be confirmed
30.	Management Office of Provident Centre	23 Wharf Road, North Point, Hong Kong	To be confirmed
31.	Management Office of King Wah House	5-7 King Wah Road, North Point, Hong Kong	To be confirmed

(version 1.7)

Item	The Community	Address and Contact Telephone Number	Contact Person
32.	FEHD Whitfield Depot	AECOM Asia Co. Ltd. at 12th Floor, Grand Central Plaza, Tower 2 138 Sha Tin Rural Committee Road Sha Tin, New Territories, Hong Kong or Public Relations Unit, Headquarters 5th floor, Ho Man Tin Government Offices 88 Chung Hau Street Ho Man Tin, Kowloon.	Mr. Charlton Wong

(version 1.7)

B. Causeway Bay CLG members from the community of the Causeway Bay area

Item	The Community	Address and Contact Telephone Number	Contact Person
1.	Management Offices of Prospect Mansion	66-72 Paterson Street, Causeway Bay	To be supplemented
2.	Management Offices of Welcome Mansion	58-64 Paterson Street, Causeway Bay	To be supplemented
3.	Management Offices of Towing Mansion	50-56 Paterson Street, Causeway Bay	To be supplemented
4.	Management Offices of Causeway Bay Mansion	42-48 Paterson Street, Causeway Bay	To be supplemented
5.	Management Offices of Miami Mansion	13-15 Cleveland Street, Causeway Bay	To be supplemented
6.	Management Offices of Florida Mansion	9-11 Cleveland Street, Causeway Bay	To be supplemented
7.	Management Offices of Cleveland Mansion	5-7 Cleveland Street, Causeway Bay	To be supplemented
8.	Management Offices of Hamilton Mansion	1-3 Cleveland Street, Causeway Bay	To be supplemented
9.	Management Offices of Highland Mansion	8 Cleveland Street, Causeway Bay	To be supplemented
10.	Management Offices of Marco Polo Mansion	10 Cleveland Street, Causeway Bay	To be supplemented
11.	Management Offices of Newtown Mansion	6 Cleveland Street, Causeway Bay	To be supplemented
12.	Management Offices of Victoria Park Mansion	15 Kingston Street, Causeway Bay	To be supplemented
13.	Management Offices of Clarke Mansion	9 Kingston Street, Causeway Bay	To be supplemented
14.	Management Offices of Chesterfield Mansion	11 Kingston Street, Causeway Bay	To be supplemented
15.	Management Offices of Riviera Mansion	59-65 Paterson Street, Causeway Bay	To be supplemented
16.	Management Offices of Haywood Mansion	57 Paterson Street, Causeway Bay	To be supplemented
17.	Management Offices of Vienna Mansion	55 Paterson Street, Causeway Bay	To be supplemented

(version 1.7)

Item	The Community	Address and Contact Telephone Number	Contact Person
18.	Management Offices of Hyde Park Mansion	53 Paterson Street, Causeway Bay	To be supplemented
19.	Management Offices of Fairview Mansion	51 Paterson Street, Causeway Bay	To be supplemented
20.	Excelsior Hong Kong	281 Gloucester Road, Causeway Bay	To be supplemented
21.	World Trade Centre	280 Gloucester Road, Causeway Bay	To be supplemented
22.	Management Office of Windsor House	311 Gloucester Road, Causeway Bay	To be supplemented
23.	Management Office of Hoi Deen Court	276-279 Gloucester Road, Causeway Bay	To be supplemented
24.	Management Office of Hoi Tao Court	271-275, Gloucester Road, Causeway Bay	To be supplemented
25.	Management Office of Hoi Kung Court	264-269 Gloucester Road, Causeway Bay	To be supplemented
26.	Top Glory Tower	262 Gloucester Road, Causeway Bay	To be supplemented
27.	Sino Plaza	256-257 Gloucester Road, Causeway Bay	To be supplemented
28.	Management Office of Elizabeth House	250-254 Gloucester Road, Causeway Bay	To be supplemented
29.	Royal Hong Kong Yacht Club	Royal Hong Kong Yacht Club, Causeway Bay	To be supplemented
30.	Police Officers' Club	Police Officers' Club, Causeway Bay	To be supplemented
31.	Operations Branch of Water Supplies Department	Hong Kong and Islands Regional Office WSD Hong Kong Regional Building 611 King's Road, North Point Tel: 2880 2555	CE/HK Mr Yeung Sek Kui

(version 1.7)

Item	The Community	Address and Contact Telephone Number	Contact Person
32.	Hong Kong Transport, Logistics & Management Co. Ltd	Administration Building Cross-Harbour Tunnel Hungghom, Kowloon, Hong Kong	To be supplemented
33.	Causeway Bay Typhoon shelter Mutual Aid Committee	To be confirmed	To be supplemented
34.	Hong Kong Cargo-Vessel Traders' Association Limited	2/F, 21-23 Man Wai Building, Man Cheong Street	To be supplemented
35.	Hong Kong Pilots Association	1601-1606, Hong Kong Plaza, 186-191 Connaught Road West, Hong Kong.	To be supplemented
36.	Owners of temporary structures at CBTS	To be confirmed	To be supplemented
37.	香港漁民近岸作業協會	Rm 1209, Sui Yick hse, Siu Sai Wan Est, Chai Wan Tel: 9088 8728	Mr. Lai Tai Hei
38.	銅鑼灣廟船	To be confirmed	To be supplemented
39.	海上業界聯席會議	To be confirmed	To be supplemented
40.	港九電船拖輪商會	46 & 48 Man Cheong Bldg., 3/F., Ferry Point, Kowloon, Hong Kong .	To be supplemented
41.	海上遊覽業聯會	Rm 1615, One Grand Tower, 639 nathan Rd, Mong Kok Tel: 9484 5417	張有光

(version 1.7)

C. Wan Chai CLG members from the community of the Wan Chai area

Item	The Community	Address and Contact Telephone Number	Contact Person
1	Hong Kong Convention and Exhibition Centre (Management) Ltd	Tel.: 2582 7070	P K Chan
2	Kiu Lok Service Management Co. Ltd.	Room 1108, Office Tower, Convention Plaza, 1 Harbour Road, Wan Chai Tel: 2802 7966	Mr. C. K. Wu
3	Management Office of the Hong Kong Academy for Performing Arts	1 Gloucester Road, Wan Chai Tel: 2584 8500	Mr. Joseph Law
4	Management Office of Hong Kong Arts Centre	2 Harbour Road Tel.:2584 8690	Mr. Kwok
5	Management Office of Shui On Centre	Room 102, 1/F, Shui On Centre, 6-8 Harbour Road, Hong Kong Tel: 2879 1803	Ms. Eva Wong
6	Management Office of Sun Hung Kai Centre	26/F., Sun Hung Kai Centre, 30 Harbour Road, Wan Chai Tel: 2828 5218	Mr. Ricky Kwan
7	Management Office of Great Eagle/Harbour Centre	Suite 3206, Great Eagle Centre, 23 Harbour Road, Wan Chai Tel: 2879 2118 (for Great Eagle Centre) 26/F., Sun Hung Kai Centre, 30 Harbour Road, Wan Chai Tel: 2828 0852 (for Harbour Centre)	Ms. Polly Lo Mr. S. C. Ip
8	Management Office of China Resources Building	Room 4206-10, 42/F., China Resources Building, 26 Harbour Road, Hong Kong Tel: 2828 5688	Mr. Dave Law
9	Management Office for Convention Plaza Apartments	Convention Plaza Apartments, 1 Harbour Road, Wan Chai Tel.: 2829 7098	Mr. George Lau
10	Telecom House (managed by REACH)	19 th Floor, Telecom House, 3 Gloucester Road, Wan Chai Tel: 2983 3719	Mr. Herrick Chong

(version 1.7)

Item	The Community	Address and Contact Telephone Number	Contact Person
11	Grand Hyatt Hong Kong Hotel	1 Harbour Road Hong Kong Tel.:2584 7021	Mr. Kwong
12	Renaissance Harbour View Hotel	1 Harbour Road, Wanchai Tel.:2802 8888	Ms. Siu
13	Management Office of Central Plaza	Suite 2802, 28/F, Central Plaza 18 Harbour Road, Wanchai, Hong Kong Tel.:2586 8111	To be confirmed
14	Society for the Prevention of Cruelty to Animals Hong Kong, SPCA(HK)	5, Wan Shing Street, Wan Chai Tel.: 2232 5516	Ms. Leung
15	Management Office of Causeway Bay	Block A, Causeway Centre 28 Harbour Road, Wan Chai	To be confirmed
16	ECO gas station at Wan Shing Street	To be confirmed	To be confirmed
17	Operations Branch of Water Supplies Department	To be confirmed	To be confirmed
18	Representative of EMSD (for the operation of the seawater cooling system for the government offices at Wan Chai North)	Electrical and Mechanical Services Department 3 Kai Shing Street, Kowloon, Hong Kong Tel: 3155 4304	Mr. Ernest Li
19	Representative of LCSD (for the operation of the Wan Chai Sports Ground)	Tel.:2827 7720	Ms. Mabel Chan

D. Central CLG members from the community of the Central area

Item	The Community	Address and Contact Telephone Number	Contact Person
1.	IFC	1 Harbour View Street	To be supplemented
2.	Four Seasons Hotel Hong Kong and Four Seasons Place	8 Finance Street, Central	To be supplemented
3.	Management Offices of the Bauhinia (Korea Centre)	119-120 Connaught Rd Central, Sheung Wan	To be supplemented

Appendix F
Proposal for Real-time
Noise Monitoring System



CONTRACT NO: HK/2009/05

**WANCHAI DEVELOPMENT PHASE II AND
CENTRAL WANCHAI BYPASS
SAMPLING, FIELD MEASUREMENT AND TESTING
WORK (STAGE 1)**

**PROPOSAL ON THE REAL-TIME NOISE
MONITORING SYSTEM**

CLIENTS:

**Civil Engineering and Development
Department**

and

Highways Department

PREPARED BY:

Lam Geotechnics Limited

11/F Centre Point
181-185 Gloucester Road,
Wanchai, H.K.

Telephone: (852) 2882-3939

Facsimile: (852) 2882-3331

E-mail: info@lamenviro.com

Website: <http://www.lamenviro.com>

CHECKED BY:

Raymond Dai
Environmental Team Leader

DATE:

2 July 2010



Proposal on the Real-time Noise Monitoring System

1. Introduction

According to Condition 2.5(c) of EP-356/2009 and Condition 2.5(b) and EP-364/2009, a real-time on-site monitoring system of the noise level around the works sites shall be set up at North Point and Tin Hau areas during the construction phase. This proposal presents the details of system configuration and installation details for the real time on site monitoring system.

2. Equipments

Component equipments of the real-time noise monitoring are listed below. Details of equipments are as follows. Specifications of proposed equipments are shown in **Appendix A**.

- Bruel & Kjaer Handheld Analyzer 2250 Light Model no. 2250-L-400 (Hand-held Analyzer with Sound Level Meter Software BZ-7130, logging software BZ-7133 and Utility Software for Hand-held Analyzers, BZ-5503);
- Bruel & Kjaer outdoor microphone kit UA-1404;
- Sound Level Calibrator
- 3m Microphone Extension Cable
- Rechargeable battery for power supply;
- Wireless modem (GPS or equivalent mechanism)
- Weatherproof Cabinet; and
- Equipment power converter for battery 12V to 5V (if necessary)
- Rechargeable battery (12V, 50AH) for location where a/c supply cannot be obtained (From supplier information, 12V battery can supply normally 30-40days in this real-time noise monitoring set-up and the battery condition could be indicated by the screen of SLM.)
- Weatherproof Cabinet of approximate dimension (roughly 0.25m X 0.4m X 0.5m) to house all the necessary equipment

3. Proposed Monitoring Stations

The proposed real-time noise monitoring stations for EP- 356/2009 and EP-364/2009 are summarized as below. The proposed locations of monitoring stations are enclosed in **Appendix B**.

Table 3.1 Summary of the proposed monitoring stations

EP	District	Monitoring Location	Measurement Type	Commencement of Monitoring
EP-356/2009	Tin Hau	Tung Lo Wan Fireboat Station	Façade Measurement	Land-based pilling and filling works
	North Point	Oil Street Community Liaison Centre	Free-field Measurement	Land-based pilling and filling works



EP	District	Monitoring Location	Measurement Type	Commencement of Monitoring
EP-364/2009	Tin Hau	Tung Lo Wan Fireboat Station	Façade Measurement	CWB Pilling works
		Causeway Bay Community Centre	Façade Measurement	IECL Bridge Demolition
	North Point	Oil Street Community Liaison Centre	Free-field Measurement	IECL Bridge Demolition
		Hong Kong Baptist Church Henrietta Secondary School	Free-field Measurement	IECL Bridge Demolition

For free-field measurement at Oil Street Community Liaison Centre and Hong Kong Baptist Church Henrietta Secondary School, additional 3dB(A) shall be made on the measured results.

4. Set-up Monitoring Stations

- The sound level meter, GSM modem, power converter and rechargeable battery should be stored inside the weatherproof cabinet to protect from sunlight and rain.
- Rechargeable battery and Converter should be provided for the power supply of the sound level meter and wireless modem.
- Outdoor microphone kit UA-1404 is a weather-proof microphone and suitable for semi-permanent, unsupervised outdoor installation. It is effective to protect the microphone from wind, rain, chemical resistant and birds during the real-time noise monitoring.
- Outdoor microphone should be mounted a mast connects to the sound level meter inside weatherproof cabinet. The mast shall be mounted on parapet wall at the premise. Schematic drawing of the monitoring equipments and proposed locations of monitoring stations are enclosed in **Appendix B**.

5. Methodology

- Liaison with the appropriate Noise Sensitive Receivers (NSRs) at North Point and Tin Hau to set up a real time on site noise monitoring on their premise.
- After obtained approval from the NSR, setting-up of equipments on-site shall be prior to the commencement of construction phase as stated in **Table 3.1**.
- Testing and commissioning of the stations shall be conducted for at least 14 works days before the commencement of the monitoring station.
- The on-site monitoring system shall be automatically conducted for 24 hours a day.
- Noise level shall be measured in term of the A-weighted equivalent continuous sound pressure level L_{eq} . $L_{eq(30min)}$ shall be used as the monitoring parameter for the time period between 0700-1900 hrs in normal weekdays. $L_{eq(5min)}$ shall be used for the measurement during all days during 1900 – 0700 hrs and general holiday 0700 – 2300 hrs.
- As supplementary information for data auditing, L_{10} and L_{90} shall be also obtained for reference.
- The noise data shall be transmitted through GSM wireless communication or equivalent device to head office computer server by mobile dial up mechanism (Relevant information is shown in **Appendix A**).



- h) The data shall be audited within two working days of sampling and audited data shall be posted onto EM&A website for public access two working days after sampling
- i) Calibration check of sound level meter shall be conducted once every two weeks. Laboratory calibration of sound level meters and calibrator shall be conducted annually.
- j) For public safety, the microphone extension shall be disassembled upon the hoisting of typhoon signal No. 3 or above and no data shall be captured until the microphone is re-assembled when the typhoon signal is removed. Moreover, it is not sensible to capture noise data during the typhoon period as the data are not representative.
- k) Regular checking of monitoring stations and renew rechargeable battery shall be maintained at least every two weeks so as to keep the consistency of the real time noise monitoring.

6. Compliance Checking of Noise Data

- a) In order to avoid the erroneous noise data, background noise shall be studied before the commencement of the construction works as described in **Table 3.1**.
- b) For the review of background noise, it is recommended to obtain 14 days during the period of non-construction hours for both non-restricted hours and restricted hours. The non-constructed hours are defined as the time without any construction works near the monitoring station. The duration of selected time periods for the comparison and elimination of background noise from measured noise level is shown as **Table 6.1**. The measured noise levels obtained in these periods will be compared with the background noise level of the same period obtained during the non-construction hours. The actual non-construction hours will be determined with the Contractor works programme.

Table 6.1 Duration of selected periods for comparison

Time Periods	Period for Non-constructed Hours
Non-restricted hours	0700-1000hrs (normal weekdays)
	1000-1700hrs (normal weekdays)
	1700-1900hrs (normal weekdays)
Restricted hours	1900-2300hrs (all days)
	2300-0700hrs (all days)
	0700-1900hrs (Sunday and Public Holiday)

- c) The duration and parameter of background noise shall be in term of $L_{eq(30min)}$ during the period of 0700-1900 hours on normal weekday and $L_{eq(5min)}$ during the period other than 0700-1900 hours on normal weekday. It shall be as a factor to eliminate the background noise from the measured noise level.
- d) Compliance checking of the corrected noise level shall be applied to the normal construction hours 0700-1900 hrs between Monday and Saturday.
- e) It shall be also applied to the restricted hour if any construction works conducted with valid CNP during this period.



- f) In case of any action and limit level exceedances occur, the exceeded noise level will be analysed and reviewed any relationship with the construction works. Shall the non-compliance occurs, action shall be taken in accordance with the Event/Action Plan stipulated in EM&A Manual.



APPENDIX A

SPECIFICATIONS OF PROPOSED EQUIPMENTS

PRODUCT DATA

2250 Light – with Sound Level Meter Software BZ-7130
Optional Software: 1/1-oct. Frequency Analysis BZ-7131,
1/3-oct. Frequency Analysis BZ-7132 and Logging BZ-7133

2250 Light has been developed specifically for measuring occupational, environmental and product noise, while complying fully with all the relevant national and international standards.

Extensive user studies have been paired with state-of-the-art technology to make this analyzer a robust, effective and elegant tool for those applications.

Using the large, high contrast, touch screen interface, the analyzer can easily be set up to display and measure just what is needed from the extensive list of parameters provided by the analyzer.

2250 Light comes with Sound Level Meter Software installed, measuring all parameters simultaneously within its wide 120 dB dynamic range. For frequency analysis, add the 1/1- and/or 1/3-octave software module. For time profile investigation, add the Logging software module. The optional software modules install easily and work seamlessly with the Sound Level Meter Software.

Back in the office, USB connectivity lets you use your PC to archive, manage, view or even control 2250 Light, as well as export your results to software packages such as Microsoft® Excel and Brüel & Kjær Types 7815, 7820 or 7825 for post-processing and reporting.



Uses and Features

USES

- Environmental noise assessment, monitoring and complaints
- Occupational noise evaluation
- Selection of hearing protection
- Noise reduction
- Product quality control
- General purpose Class 1 sound measurements
- Real-time analysis of sound in 1/1- and 1/3-octave bands
- Analysis of time histories for broadband parameters and spectra (Logging)

FEATURES

- Large, high-resolution, touch-sensitive screen
- 'Traffic Light' status indicator
- Plug-in rechargeable Li-ion battery
- Data storage on plug-in memory cards
- 120 dB dynamic range – up to 140 dB
- Real-time frequency analysis in 1/1-octave bands
- Real-time frequency analysis in 1/3-octave bands
- Broadband and spectrum logging
- Logging profile display with markers
- Back-erase to delete unwanted noise events
- PC software included for archiving, export and reporting
- Robust and environmentally protected (IP 44)
- Upgrade to Type 2250 on exchange basis

Introduction

2250 Light combines renowned Brüel & Kjær measurement excellence and the Type 2250 platform's ease of use, in an efficient and versatile sound measurement instrument. Whether you are addressing workplace noise compliance, environmental noise assessment, or product noise certification, 2250 Light offers the functionality to meet your requirements. A unique user-interface makes your measurements easier to perform with results that are easier to analyze and report.

This data sheet describes the suite of software applications available for 2250 Light. All instruments come with the Sound Level Meter Software for 2250 Light (BZ-7130) included.

Note: 2250 Light can be upgraded to a Type 2250 Hand-held Analyzer, to include more features and applications such as advanced logging, sound recording or reverberation time software. Please refer to Type 2250 Product Data BP 2025 for more information. The upgrade is on an exchange basis, please contact your local Brüel & Kjær representative for details.

Applications

Workplace and Industrial Hygiene Noise Measurement Applications

2250 Light was developed with special interest for the measurement of workplace noise. The comfortable and secure design feels safe in your hand. With the display located relatively close to you, the buttons fall precisely where they need to be for a one thumb operated Start, Stop and Save. The 'Traffic Light' indicator surrounding the Start/Pause pushbutton gives you an immediate visual indication of measurement status – even in the brightest sunshine. The large, high contrast, touch screen/display, lets you select parameters on the display, and 2250 Light can memorise those setups for your next measurement.



As for occupational health noise parameters, nothing was left out. 2250 Light can measure Fast and Slow, A-weighted and C-Weighted SPLs simultaneously, along with a separately weighted peak detector, so that the values you need to specify hearing protection are immediately on the display. Parallel analysis allows you to compare a 3 dB exchange rate average measurement with a selectable alternate 4, 5 or 6 dB exchange rate, including separate dose, expected dose and exposure values.

2250 Light also offers three independent threshold peak event counters, along with simultaneous Fast, Slow and Impulse RMS detectors, to assess impulsive noise.

When you add the optional 1/1-octave frequency analysis software option, you are ready to instantly assess noise control and detailed hearing protection requirements for a surveyed location. With 2250 Light there is no filter switching, or range changing, all the octaves are measured at the same instant, along with the broadband A- and C-weighted values. For even more detail, add the 1/3-octave frequency analysis option. Instantly see the maximum and average levels across 31 frequency bands spanning three decades from 12.5 Hz to 16 kHz.

Sometimes noise levels in the workplace vary dramatically, and perhaps irregularly. To assess this kind of noise it is helpful to measure and analyse a noise profile – a measurement that shows how the sound varies with time.

The Logging option for 2250 Light provides this capability in a naturally intuitive way, using simultaneous views of the complete profile and a ‘zoomed-in’ 100-second ‘window’. Set up to five different user-defined markers anywhere in the profile, to identify noise sources or events. If you have installed either the 1/1- or 1/3-octave real-time frequency analysis options, 2250 Light seamlessly integrates the spectrum information into the noise profile.

Back at your desk after a survey, or even a single measurement, archive the measurements using the included utility program, where you can view all the results of your measurement on a Windows® compatible PC. Use the same utility program to transfer measurement results to Excel to easily produce reports, or export the results directly to Brüel & Kjær’s Protector Type 7825, where you can organise and analyze the company’s noise and hearing conservation program. Type 7825 calculates noise exposure according to ISO 9612.2.

So, whether you are making a simple noise survey, or supplementing noise dose measurements for noise control or hearing protection selection, 2250 Light is an easy, yet powerful tool to make you more productive, and more confident in analysing hearing conservation programs.

Environmental Noise Measurement Applications

The tasks for environmental noise measurements are varied, so the instrument you pick for your measurements needs to be flexible, easy to configure, powerful and accurate. 2250 Light is all that, and more, making it ideal for a simple noise enforcement measurement one moment, then a complex environmental impact survey the next. 2250 Light is built on the core platform of the award winning design of Type 2250. It borrows the robust construction, intuitive touch screen interface, and legendary Brüel & Kjær measurement accuracy.



2250 Light with the standard Sound Level Meter software (BZ-7130) is ideal for a spot noise enforcement check. Use the large numeric display, press the conveniently located Start pushbutton, and when ready, press the same button to stop the measurement. Press the Save pushbutton, and you will not only be saving the results, but also the actual time of the measurement, its duration, and even the date and time for the last calibration of the instrument.

2250 Light can measure all the parameters needed for environmental noise, including dual frequency weightings, Fast, Slow, and Impulse Time Averaging, L_{eq} 's and a full range of statistical distributions. But just as important, you can set 2250 Light to display just the parameters you need, then save that display so 2250 Light powers-up, tailor-made for your use, every time.

For more involved environmental applications, you'll need to add the Logging option. Now you can set the instrument to record all, or up to ten selected measurement results at intervals from one second to one day, for a duration only limited by the size of the CF or SD memory card used in the external memory slots. The display offers two simultaneous views, one of

the complete profile and a 'zoomed-in' 100-second 'window', that are intuitively linked by the cursor.

For the precise timing of noise events, an alternative 'Fast Log' view gives you either or both of the L_{AF} and L_{Aeq} results for 100 ms intervals. In either the fast log, or profile view, you can define up to five different markers anywhere in the profile, to identify noise sources or events. When you use the real-time frequency analysis options, 1/1-octave or 1/3-octave, the frequency spectrum average, maximum and minimum values can be logged along with the overall values. Save and view the noise profiles on your Windows® PC with the included utility program, or for easy analysis of the noise profile, export the whole measurement to Brüel & Kjær Environmental Noise Software (Type 7820 Evaluator or Type 7821 Evaluator Light) which have built-in calculation algorithms that allow you to produce compound sound level figures from several contributions. Some may have impulse or pure tone penalties, depending on which measurement standard you choose, for example, ISO 1996, DIN 45 645, TA Lärm, NF S 31-010, or BS 4142. (See Product Data BP 1752.)

You'll take these measurements with the incredible 120 dB dynamic range of 2250 Light, allowing measurements from the low noise floor of the instrument to over 140 dB. Without a range switch to consider, you can now make measurements without fear of overload, and still capture the nuances of a silent night. 2250 Light is an ideal entry point to safe, easy and precise environmental noise measurements.

Product Noise Measurement

Brüel & Kjær long ago set the standard for product noise measurements. Now, whether you have a simple A-weighted sound limit requirement, or need to evaluate a 1/3-octave reverberation chamber sound power test, 2250 Light is scalable to your requirements.



2250 Light can be used as a hand-held device for easy portability, or it can be operated using your Windows® PC as an on-line USB controlled device in your laboratory. The user-defined templates make switching between applications easy.

The wide 120 dB dynamic range of 2250 Light eliminates concern for overloads, and you can set a preset measurement time to add consistency to your measurements. Use the built-in headphone style (3.5 mm) output jack to send the signal out to other measurement instrumentation. The included utility program makes it easy to keep track of results in an organised, archive structure. And, of course, there's the Class 1 precision and reputation of Brüel & Kjær, giving you and your customers' complete confidence in your measurements, while adding value to your products.

For comprehensive data management and post-process reporting, consider using 2250 Light data together with Type 7815 Noise Explorer, which supports a wide range of user-definable graphic and tabular displays.

Graphs and tables can be imported into standard Windows® applications such as word processors and spreadsheets.

Fig. 1 Key features of 2250 Light



060202

Fig. 2
The large numeric display - ideal for a spot noise enforcement check

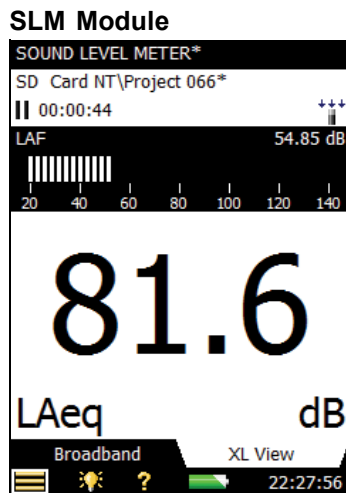

2250 Light comes with the Sound Level Meter Software for 2250 Light included. This makes 2250 Light into a versatile broadband sound level meter; it complies with the latest international standard (IEC 61672-1) as well as previous international and national standards.

All quantities are measured at the same time. For example, A and C frequency weighted levels are measured simultaneously, and at the same time F, S and I time weightings are applied in parallel. In addition, Peak levels are measured. Full statistics are also computed on-the-fly. Combine this with the dynamic range exceeding 120 dB and you will never miss a beat! You get all the parameters in one attempt, under-range is non-existent and you will have difficulties provoking an overload.

A full compliment of occupational health sound parameters are provided simultaneously, complying with national and international standards. The detailed list of available parameters can be found in the specifications section. You choose what you want on the display, but, at any time – during or after the measurement – all other parameters can be inspected and reported.

1/1- and 1/3-octave Frequency Analysis Software for 2250 Light – BZ-7131 and BZ-7132

Fig. 3
Example of 1/1-octave frequency analysis. Note that two spectra are displayed simultaneously

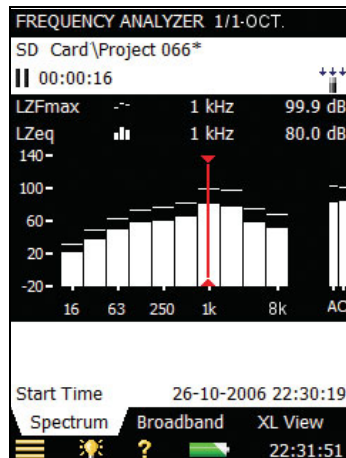

1/1-octave Frequency Analysis Software for 2250 Light BZ-7131, and 1/3-octave Frequency Analysis Software for 2250 Light BZ-7132 are optional software modules. They allow you to make real-time measurements in 1/1- or 1/3-octave bands over a wide frequency range. This makes it a simple matter to obtain spectra in order to, for example, select hearing protection, qualify heat and ventilation systems, and assess tonality.

The following frequency ranges are available:

- 1/1-octave spectra (centre frequencies 16 Hz to 8 kHz)
- 1/3-octave spectra (centre frequencies 12.5 Hz to 16 kHz)

In each band you have a full and unrivalled dynamic range from the noise floor in that particular band to 140 dB. That is, a dynamic range generally in excess of 135 dB.

Spectra can be A-, B-, C- or Z-weighted. Five spectra are measured and stored and, in addition, two instantaneous spectra are available for display. Two spectra, for example, a minimum and maximum spectrum, can be superimposed on the display. All the broadband quantities measured by Sound Level Meter Software BZ-7130 are computed in parallel with the frequency analysis.

Logging Software for 2250 Light – BZ-7133

Fig. 4
Display showing part of a logging profile and an exclude marker

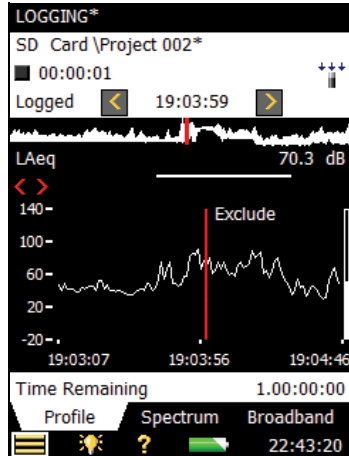

With the optional Logging Software enabled, 2250 Light becomes a versatile instrument for obtaining time histories. The Logging Software allows you to select freely among the broadband parameters and log them at intervals from 1 s to 24 h. At the same time L_{Aeq} and/or L_{AF} can be logged at 100 ms intervals.

If Frequency Analysis Software BZ-7131 or BZ-7132 is enabled, the Logging Software additionally lets you log spectra at the same 1 s to 24 h intervals.

Logging Software BZ-7133 incorporates a number of features designed to make difficult field work as manageable as possible.

Among the most salient of these features are the following:

- Five user-definable markers can be set on-the-fly in the profile. Use these, for example, to clearly indicate specific noise sources or events
- Markers can be set directly on the profile display using the stylus and the touch screen. Simply ‘tap and drag’ on the part of the profile you want to mark and select a marker from the drop-down list
- Three of the markers can also be set using the three marker pushbuttons
- Markers can even be set ‘after the fact’. The display covers the latest 100 samples (that is, 100 s of profile when logging at 1 s intervals, otherwise more) meaning that in most cases you can wait for the event (or disturbance) to stop before placing your marker. Alternatively, scroll back in the profile and set your marker
- Lets you browse easily between markers
- The profile display can be ‘frozen’ at any time (this happens automatically when you tap the screen), allowing you to work at ease

All markers are saved with the measurement, see Fig. 4. No further bookkeeping is required. When exporting data to, for example, 7821 Evaluator Light software for further analyses, markers are directly accessible on the profile.

Data is stored directly on SD or CF cards; for availability, please refer to the Ordering Information. Data can be directly read from the memory card by the included PC software BZ-5503 (see following section). This means that even large amounts of data can be quickly transferred to a PC.

In order to give an indication of the amount of memory required, some examples have been listed below. Values should be compared to the standard size of the SD cards used, which start at 128 Mbyte.

For convenience, values for 1 s logging periods during 24 h are given. Other values easily compute from these:

- Five broadband parameters, no statistics: 1 Mbyte
- All broadband parameters, one 100 ms parameter: 3 Mbyte
- All broadband parameters, no statistics: 4 Mbyte
- All broadband parameters, one 100 ms parameter, all 1/3-octave spectra: 30 Mbyte
- All broadband parameters with full statistics: 58 Mbyte
- All broadband parameters, one 100 ms parameter, all 1/3-octave spectra, full statistics: 86 Mbyte

Type 2250 PC Software – Utility Software for Hand-held Analyzers BZ-5503

Utility Software for Hand-held Analyzers BZ-5503 is an archiving tool for 2250 Light data and setups, and functions as the link between 2250 Light and post-processing or reporting software on a PC. It enables you to do the following:

- Control 2250 Light from a PC
- Manage and archive data on a PC
- Keep your 2250 Light software up to date



Overview of 2250 Light Software Features

The table that follows presents a summary of the features of each of the software modules available with 2250 Light. See Specifications for details.

Feature	SLM Software (Included)	1/1-octave Frequency Analysis Software	1/3-octave Frequency Analysis Software	Logging Software
120+ dB Dynamic Range – no need for range switching	•	•	•	•
Sound levels up to 140 dB with supplied Microphone Type 4950	•	•	•	•
IEC/ANSI SLM standards Type/Class 1	•	•	•	•
Frequency weightings A, B, C, Z (linear) and time weightings F, S, I	•	•	•	•
Free-field/diffuse-field correction	•	•	•	•
Pre-set time start/stop	•	•	•	•
Back-erase – last 5 seconds of measurement data	•	•	•	
Multi-language user interface	•	•	•	•
Context-sensitive help	•	•	•	•
Broadband statistics based on L_{Aeq} , L_{AF} or L_{AS}	•	•	•	•
Broadband frequency range: 5 Hz – 18 kHz	•	•	•	•
Remote control using Analogue or GSM modem	•	•	•	•
Transfer of data files while measuring (USB or modem)	•	•	•	•
1/1-octave spectra (centre frequencies 16 Hz to 8 kHz)		•		• ^a
1/3-octave spectra (centre frequencies 12.5 Hz to 16 kHz)			•	• ^a
Logging of all or selected broadband parameters and spectra				•
Logging period 1 s to 24 h				•
L_{Aeq} and/or L_{AF} logged every 100 ms				•
Profile display				•
Profile overview of entire measurement				•
Markers on profile display				•

a. If 1/1- or 1/3-octave Frequency Analysis Software is enabled

Compliance with Standards

 	CE-mark indicates compliance with the EMC Directive and Low Voltage Directive. C-Tick mark indicates compliance with the EMC requirements of Australia and New Zealand.
Safety	EN/IEC 61010-1: Safety requirements for electrical equipment for measurement, control and laboratory use. UL 61010B-1: Standard for Safety – Electrical measuring and test equipment.
EMC Emission	EN/IEC 61000-6-3: Generic emission standard for residential, commercial and light industrial environments. CISPR 22: Radio disturbance characteristics of information technology equipment. Class B Limits. FCC Rules, Part 15: Complies with the limits for a Class B digital device. IEC 61672-1, IEC 61260, IEC 60651 and IEC 60804: Instrumentation standards
EMC Immunity	EN/IEC 61000-6-2: Generic standard – Immunity for industrial environments. EN/IEC 61326: Electrical equipment for measurement, control and laboratory use – EMC requirements. IEC 61672-1, IEC 61260, IEC 60651 and IEC 60804: Instrumentation standards

Specifications – 2250 Light Platform

Specifications apply to 2250 Light fitted with Microphone Type 4950 and Microphone Pre-amplifier ZC-0032

SUPPLIED MICROPHONE

Type 4950: Pre-polarized Free-field ½" Microphone
Nominal Open-circuit Sensitivity: 50 mV/Pa (corresponding to -26 dB re 1 V/Pa) ± 2 dB
Capacitance: 12.5 pF (at 250 Hz)

MICROPHONE PREAMPLIFIER ZC-0032

Nominal Pre-amplifier Attenuation: 0.3 dB
Connector: 10-pin LEMO
Extension Cables: Up to 100 m in length between the microphone pre-amplifier and 2250 Light, without degradation of the specifications

SELF-GENERATED NOISE LEVEL

Typical values at 23°C for nominal microphone open-circuit sensitivity:

Weighting	Microphone	Electrical	Total
"A"	14.0 dB	12.9 dB	16.4 dB
"B"	12.9 dB	11.8 dB	15.4 dB
"C"	13.0 dB	13.4 dB	16.2 dB
"Z" 5 Hz–20 kHz	14.4 dB	19.2 dB	20.4 dB

KEYBOARD

Pushbuttons: 11 keys with backlight, optimised for measurement control and screen navigation

ON-OFF BUTTON

Function: Press 1 s to turn on; press 1 s to enter standby; press for more than 5 s to switch off

STATUS INDICATORS

LEDs: Red, amber and green

DISPLAY

Type: Transflective back-lit touch screen 240 × 320 dot matrix
Black and White Scheme
Backlight: Adjustable level and on-time

USER INTERFACE

Measurement Control: Using pushbuttons on keyboard
Setup and Display of Results: Using stylus on touch screen or pushbuttons on keyboard
Lock: Keyboard and touch screen can be locked and unlocked

USB INTERFACE

USB 1.1 OTG Mini B socket

MODEM INTERFACE

Hayes compatible GSM or standard analogue modems connected through the Compact Flash slot

INPUT SOCKET

Connector: Triaxial LEMO
Input Impedance: ≥ 1 MΩ
Direct Input: Max. input voltage: ±14.14 V_{peak}

HEADPHONE SOCKET

Connector: 3.5 mm Mini-jack stereo socket
Max. Peak Output Level: ± 1.4 V
Output Impedance: 32 Ω in each channel

EXTERNAL DC POWER SUPPLY REQUIREMENTS

Used to charge the battery pack in the instrument
Voltage: 8–24 V DC, ripple voltage < 20 mV
Current Requirement: min. 1.5 A
Power Consumption: < 2.5 W, without battery charging, < 10 W when charging
Cable Connector: LEMO Type FFA.00, positive at centre pin

BATTERY PACK

Type: Li-Ion rechargeable
Typical Operating Time: > 8 hours

STORAGE SYSTEM

Internal Flash-RAM (non-volatile): 20 Mbyte for user setups and measurement data
External Secure Digital Memory Card (SD-card): For store/recall of measurement data
External Compact Flash Memory Card (CF-card): For store/recall of measurement data

CLOCK

Back-up battery powered clock. Drift < 0.45 s per 24 hour period

WARM-UP TIME

From Power Off: < 2 minutes
From Standby: < 10 seconds

TEMPERATURE

IEC 60068-2-1 & IEC 60068-2-2: Environmental Testing. Cold and Dry Heat
Operating Temperature: -10 to +50°C (14 to 122°F), < 0.1 dB
Storage Temperature: -25 to +70°C (-13 to +158°F)

HUMIDITY

IEC 60068-2-78: Damp Heat: 90% RH (non-condensing at 40°C (104°F)).
Effect of Humidity: < 0.1 dB for 0% < RH < 90% (at 40°C (104°F) and 1 kHz)

MECHANICAL

Environmental Protection: IP 44
Non-operating:
IEC 60068-2-6: Vibration: 0.3 mm, 20 m/s², 10–500 Hz
IEC 60068-2-27: Shock: 1000 m/s²
IEC 60068-2-29: Bump: 4000 bumps at 400 m/s²

WEIGHT AND DIMENSIONS

650 g (23 oz.) including rechargeable battery
300 × 93 × 50 mm (11.8 × 3.7 × 1.9") including pre-amplifier and microphone

LANGUAGE

User Interface in Catalan, Croatian, Czech, Danish, English, Flemish, French, German, Hungarian, Japanese, Italian, Polish, Portuguese, Romanian, Serbian, Slovenian, Spanish, Swedish and Turkish

HELP

Concise context-sensitive help in Catalan, English, French, German, Italian, Japanese, Polish, Portuguese, Romanian, Serbian, Slovenian and Spanish

Software Specifications – Sound Level Meter Software for 2250 Light BZ-7130

Conforms with the following National and International Standards:

- IEC 61672–1 (2002–05) Class 1
- IEC 60651 (1979) plus Amendment 1 (1993–02) and Amendment 2 (2000–10), Type 1
- IEC 60804 (2000–10), Type 1
- IEC 61252, Electroacoustics – Specifications for Personal Sound Exposure Meters
- DIN 45657 (1997–07)
- ANSIS1.4–1983 plus ANSI S1.4A–1985 Amendment, Type 1
- ANSIS1.43–1997, Type 1

Note: The International IEC Standards are adopted as European standards by CENELEC. When this happens, the letters IEC are replaced with EN and the number is retained. 2250 Light also conforms to these EN Standards

CORRECTION FILTERS

For Microphone Type 4950:

Correct the frequency response to compensate for sound field and accessories:

Sound Field: Free-field or Diffuse-field

Accessories: None, Windscreen UA-0237

DETECTORS

Parallel Detectors on every measurement:

A- or B-weighted (switchable) broadband detector channel with three exponential time weightings (Fast, Slow, Impulse), one linearly averaging detector and one peak detector

C- or Z-weighted (switchable) as for A- or B-weighted

Overload Detector: Monitors the overload outputs of all the frequency weighted channels

MEASUREMENTS

X = frequency weightings A or B

Y = frequency weightings C or Z

V = frequency weightings A, B, C or Z

U = time weightings F or S

Q = exchange rate 4, 5 or 6 dB

N = number between 0.1 and 99.9

For Storage

Full statistics

For Display and Storage

Start Time	Stop Time	Overload %
Elapsed Time	L_{Xeq}	L_{Yeq}
L_{XE}	L_{YE}	$L_{Ceq-L_{Aeq}}$
L_{XSmax}	L_{XFmax}	L_{XImax}
L_{YSmax}	L_{YFmax}	L_{YImax}
L_{XSmin}	L_{XFmin}	L_{XImin}
L_{YSmin}	L_{YFmin}	L_{YImin}
L_{Xleq}	L_{Yleq}	$L_{Aleq-L_{Aeq}}$
L_{AFTeq}	$L_{AFTeq-L_{Aeq}}$	Time Remaining
$L_{ep,d}$	$L_{ep,d,v}$	E
Dose%	Proj. Dose%	#VPeaks (>NNNdB)
#VPeaks (>137dB)	#VPeaks (>135dB)	L_{Vpeak}
T_{Vpeak}	L_{avUQ}	TWA
TWA_v	DoseUQ%	Proj. DoseUQ%

Only for Display as Numbers or Quasi-analogue Bars

L_{XS}	L_{XF}	L_{XI}
L_{YS}	L_{YF}	L_{YI}
$L_{XS(SPL)}$	$L_{XF(SPL)}$	$L_{XI(SPL)}$
$L_{YS(SPL)}$	$L_{YF(SPL)}$	$L_{YI(SPL)}$
$L_{Vpeak,1s}$	L_{AN1} or L_{AUN1}	L_{AN2} or L_{AUN2}
L_{AN3} or L_{AUN3}	L_{AN4} or L_{AUN4}	L_{AN5} or L_{AUN5}
L_{AN6} or L_{AUN6}	L_{AN7} or L_{AUN7}	

MEASURING RANGES

Dynamic Range: From typical noise floor to max. level for a 1 kHz pure tone signal, A-weighted: 16.4 to 140 dB

Primary Indicator Range: In accordance with IEC 60651, A-weighted: 23.9 dB to 123 dB

Linearity Range: In accordance with IEC 60804, A-weighted: 21.8 dB to 140 dB

Linear Operating Range: In accordance with IEC 61672, A-weighted: 1 kHz: 25.0 dB to 140 dB

Peak C Range: In accordance with IEC 61672: 30.1 dB to 143 dB

SAMPLING FOR BROADBAND STATISTICS

The Statistics can be based on either L_{AF} , L_{AS} or L_{Aeq} :

- Statistics L_{AFN1-7} or L_{ASN1-7} are based on sampling L_{AF} or L_{AS} , resp., every 10 ms into 0.2 dB wide classes over 130 dB
- Statistics L_{AN1-7} are based on sampling L_{Aeq} every second into 0.2 dB wide classes over 130 dB

Full distribution saved with measurement

MEASUREMENT DISPLAYS

SLM: Measurement data displayed as numbers of various sizes and one quasi-analogue bar

Measured data are displayed as dB values, housekeeping data as numbers in relevant format.

Instantaneous measurement L_{XF} is displayed as a quasi-analogue bar

MEASUREMENT CONTROL

Manual: Manually controlled single measurement

Automatic: Pre-set measurement time from 1 s to 24 hours in 1 s steps

Manual Controls: Reset, Start, Pause, Back-erase, Continue and Store the measurement manually

BACK-ERASE

The last 5 s of data can be erased without resetting the measurement

MEASUREMENT STATUS

On Screen: Information such as overload and running/paused are displayed on screen as icons

Traffic Lights: Red, yellow and green LEDs show measurement status and instantaneous overload as follows:

- Yellow LED flash every 5 s = stopped, ready to measure
- Green LED flashing slowly = awaiting calibration signal
- Green LED on constantly = measuring
- Yellow LED flashing slowly = paused, measurement not stored
- Red LED flashing quickly = intermittent overload, calibration failed

CALIBRATION

Initial calibration is stored for comparison with later calibrations

Acoustic: Using Sound Calibrator Type 4231 or custom calibrator.

The calibration process automatically detects the calibration level when Sound Calibrator Type 4231 is used

Electrical: Uses internally generated electrical signal combined with a typed-in value of microphone sensitivity

Calibration History: Up to 20 of the last calibrations made are listed and can be viewed on the instrument

SIGNAL MONITORING

The input signal can be monitored using an earphone/headphones connected to the headphone socket

Headphone Signal: Input signal can be monitored using this socket with headphones/earphones

Gain Adjustment: –60 dB to 60 dB

DATA MANAGEMENT

Project Template: Defines the display and measurement setups

Project: Measurement data stored with the Project Template

Job: Projects are organised in Jobs

Explorer facilities for easy management of data (copy, cut, paste, delete, rename, view data, open project, create job, set default project name)

PREFERENCES

Date, Time and Number formats can be specified

Software Specifications – 1/1-octave Frequency Analysis Software for 2250 Light BZ-7131 and 1/3-octave Frequency Analysis Software for 2250 Light BZ-7132

The specifications for BZ-7131 and BZ-7132 include the specifications for Sound Level Meter Software for Light BZ-7130. BZ-7131 and BZ-7132 add:

STANDARDS

Conforms with the following National and International Standards:

- IEC 61260 (1995–07) plus Amendment 1 (2001–09), 1/1-octave Bands, Class 0
- ANSIS1.11–1986, 1/1-octave Bands and 1/3-octave Bands, Order 3, Type 0–C
- ANSIS1.11–2004, 1/1-octave Bands, Class 0

CENTRE FREQUENCIES

1/1-octave Band Centre Frequencies (BZ-7131 only):

16 Hz to 8 kHz

1/3-octave Band Centre Frequencies (BZ-7132 only):

12.5 Hz to 16 kHz

MEASUREMENTS

X = frequency weightings A, B, C or Z

Spectra for Display and Storage

L_{Xeq} L_{XSmax} L_{XFmax}
 L_{XSmin} L_{XFmin}

Spectra for Display Only

L_{XS} L_{XF}

Single Values

SIL PSIL SIL3
 L_{Aeq} (20-200 Hz) (BZ-7132 only)

MEASURING RANGES

Dynamic Range: From typical noise floor to max. level for a pure tone signal at 1 kHz 1/3-octave: 1.5 to 140 dB

Linear Operating Range: In accordance with IEC 61260: ≤ 20.5 dB to 140 dB

MEASUREMENT DISPLAYS

Spectrum: One or two spectra superimposed + A/B and C/Z broadband bars

Table: One or two spectra in tabular form

Y-axis: Range: 5, 10, 20, 40, 60, 80, 100, 120, 140 or 160 dB. Auto zoom or auto scale available

Cursor: Readout of selected band

Software Specifications – Logging Software for 2250 Light BZ-7133

The specifications for BZ-7133 include the specifications for Sound Level Meter Software for 2250 Light BZ-7130. BZ-7133 adds:

MEASUREMENTS

Logging: Measurement data logged at pre-set periods into files on external SD- or CF-cards

Logging Period: From 1 s to 24 hours with 1 s resolution

Fast Logging: L_{AF} and L_{Aeq} can be logged every 100 ms, irrespective of logging period

Broadband Data Stored at each Logging Interval: All, or up to 10 selectable broadband data

Broadband Statistics Stored at each Logging Interval: Full distribution, or none

Spectrum Data Stored at each Logging Interval: All, or up to 3 selectable spectra (license for BZ-7131 or BZ-7132 required)

Logging Time: From 1 second to 31 days with 1 s resolution

Measurement Total: For the logging time, in parallel with logging: All broadband data, statistics and spectra (license for BZ-7131 or BZ-7132 required)

Automatic reboot and resume of operation in case of power failure

MARKERS

Five user-definable markers for on-line marking of noise sources or events anywhere in the profile.

Markers are set using the stylus on the touch screen, or the three marker pushbuttons

MEASUREMENT DISPLAYS

Profile: Graphical display of selectable measurement data versus time. Fast display of next or previous marker, Profile Overview of entire measurement

Y-axis: Range: 5, 10, 20, 40, 60, 80, 100, 120, 140 or 160 dB. Auto zoom or auto scale available

X-axis: Scroll facilities

Cursor: Readout of measurement data at selected time

STORAGE

Measurement data is stored on an external SD or CF memory card. For availability, please refer to the Ordering Information

Software Specifications – Utility Software for Hand-held Analyzers BZ-5503

BZ-5503 is included with 2250 Light for easy synchronisation of data between PC and 2250 Light. BZ-5503 is supplied on CD-ROM BZ-5298

ON-LINE DISPLAY OF 2250 LIGHT DATA

Measurements on 2250 Light can be controlled from the PC and displayed on-line with the PC, using the same user interface on the PC as on 2250 Light

DATA MANAGEMENT

Explorer: Facilities for easy management of Instruments, Jobs and Projects (copy, cut, paste, delete, rename, create)

Data Viewer: View measurement data (content of projects)

Synchronisation: Projects can be synchronised between PC and 2250 Light

EXPORT FACILITIES

Excel: Projects (or user specified parts) can be exported to Microsoft® Excel

Type 7810/12/15/16/20/25: Projects can be exported to Predictor Type 7810, Lima Type 7812, Noise Explorer Type 7815, Acoustic Determinator Type 7816, Evaluator Type 7820 or Protector Type 7825

2250 LIGHT SOFTWARE UPGRADES AND LICENSES

The utility software controls 2250 Light software upgrades and licensing of the 2250 Light applications

INTERFACE TO 2250 LIGHT

USB ver. 1.1 or Hayes compatible GSM or standard analogue modem

PC REQUIREMENT

Operating System: Windows® 2000/Windows® XP, Microsoft® .NET
Recommended PC: Pentium® III (or equivalent) processor, 128 Mbyte RAM, SVGA graphics display/adaptor, sound card, CD ROM drive, mouse, USB, Windows® XP

Ordering Information

2250 LIGHT PACKAGES

Type 2250-L-100	Hand-held Analyzer with Sound Level Meter Software BZ-7130
Type 2250-L-200	Hand-held Analyzer with Sound Level Meter Software BZ-7130 and 1/1-octave Frequency Analysis Software BZ-7131
Type 2250-L-300	Hand-held Analyzer with Sound Level Meter Software BZ-7130, 1/1-octave Frequency Analysis Software BZ-7131 and 1/3-octave Frequency Analysis Software BZ-7132
Type 2250-L-400	Hand-held Analyzer with Sound Level Meter Software BZ-7130 and Logging Software BZ-7133
Type 2250-L-500	Hand-held Analyzer with Sound Level Meter Software BZ-7130, 1/1-octave Frequency Analysis Software BZ-7131, 1/3-octave Frequency Analysis Software BZ-7132 and Logging Software BZ-7133

SOFTWARE MODULES AVAILABLE SEPARATELY

BZ-7131	1/1-octave Frequency Analysis Software for 2250 Light
BZ-7132	1/3-octave Frequency Analysis Software for 2250 Light
BZ-7133	Logging Software for 2250 Light

COMPONENTS INCLUDED WITH TYPE 2250-L

Type 4950	Prepolarized Free-field 1/2" Microphone
ZC-0032	Microphone Preamplifier
AO-1476	USB Standard A to USB Mini B Interface Cable, 1.8 m (6 ft)
BZ-5298	Environmental Software, including BZ-5503 Utility Software for Hand-held Analyzers
ZG-0429	Mains Power Supply
QB-0061	Battery Pack Stylus

BASIC KIT FOR 2250 LIGHT (UA-1703)

FB-0691	Hinged Cover for Hand-held Analyzer
UA-0237	90 mm dia. Windscreens
DH-0696	Wrist Strap
KE-0441	Protective Cover for 2250 Light
UA-1654	5 Extra Styli

PLUS KIT FOR 2250 LIGHT (UA-1704)

FB-0691	Hinged Cover for Hand-held Analyzer
UA-0254	90 mm dia. Windscreens (6 pack of UA-0237)
UA-1673	Adaptor for Standard Tripod Mount
DH-0696	Wrist Strap
KE-0441	Protective Cover for 2250 Light
HT-0015	Earphones
UA-1654	5 Extra Styli
Type 4231	Sound Calibrator
UA-1251	Lightweight Tripod
UL-1009	SD Memory Card

ADVANCED KIT FOR 2250 LIGHT (UA-1705)

FB-0691	Hinged Cover for Hand-held Analyzer
UA-0254	90 mm dia. Windscreens (6 pack of UA-0237)
UA-1673	Adaptor for Standard Tripod Mount
DH-0696	Wrist Strap

TRADEMARKS

Microsoft and Windows are registered trademarks of Microsoft Corporation in the United States and/or other countries · Pentium is a registered trademark of Intel Corporation or its subsidiaries in the United States and/or other countries

Brüel & Kjær reserves the right to change specifications and accessories without notice.

HEADQUARTERS: DK-2850 Nærum · Denmark · Telephone: +45 4580 0500
Fax: +45 4580 1405 · www.bksv.com · info@bksv.com

Australia (+61) 2 9889-8888 · Austria (+43) 1 865 74 00 · Brazil (+55) 11 5188-8161
Canada (+1) 514 695-8225 · China (+86) 10 680 29906 · Czech Republic (+420) 2 6702 1100
Finland (+358) 9-755 950 · France (+33) 1 69 90 71 00 · Germany (+49) 421 17 87 0
Hong Kong (+852) 2548 7486 · Hungary (+36) 1 215 83 05 · Ireland (+353) 1 807 4083
Italy (+39) 0257 68061 · Japan (+81) 3 5715 1612 · Republic of Korea (+82) 2 3473 0605
Netherlands (+31) 318 55 9290 · Norway (+47) 66 77 11 55 · Poland (+48) 22 816 75 56
Portugal (+351) 21 4169 040 · Singapore (+65) 6377 4512 · Slovak Republic (+421) 25 443 0701
Spain (+34) 91 659 0820 · Sweden (+46) 33 225 622 · Switzerland (+41) 44 8807 035
Taiwan (+886) 2 2502 7255 · United Kingdom (+44) 14 38 739 000 · USA (+1) 800 332 2040

Local representatives and service organisations worldwide

KE-0441	Protective Cover for 2250 Light
HT-0015	Earphones
UA-1654	5 Extra Styli
Type 4231	Sound Calibrator
UA-1251	Lightweight Tripod
UL-1009	SD Memory Card
Type 7821	Evaluator Light

OCCUPATIONAL HEALTH KIT FOR 2250 LIGHT (UA-1706)

FB-0691	Hinged Cover for Hand-held Analyzer
UA-0254	90 mm dia. Windscreens (6 pack of UA-0237)
UA-1673	Adaptor for Standard Tripod Mount
DH-0696	Wrist Strap
KE-0441	Protective Cover for 2250 Light
HT-0015	Earphones
UA-1654	5 Extra Styli
Type 4231	Sound Calibrator
UA-1251	Lightweight Tripod
UL-1009	SD Memory Card
Type 7825	Protector

ACCESSORIES AND COMPONENTS AVAILABLE SEPARATELY

ANALYZER

ZG-0444	Charger for QB-0061 Battery Pack
---------	----------------------------------

CALIBRATION

Type 4231	Sound Calibrator (fits in KE-0440)
2250-CAI	Accredited Initial Calibration of Type 2250
2250-CAF	Accredited Calibration of Type 2250
2250-CTF	Traceable Calibration of Type 2250
2250-TCF	Conformance Test of Type 2250, with certificate

MEASURING

Type 3592	Outdoor Measuring Gear (see Product Data BP 1744)
AO-0441-D-030	Microphone Extension Cable, 10-pin LEMO, 3 m (10 ft)
AO-0441-D-100	Microphone Extension Cable, 10-pin LEMO, 10 m (33 ft)
KE-0440	Travel Bag
UA-0587	Tripod
UA-0801	Small Tripod
UA-1317	Microphone Holder
UA-1651	Tripod Extension for Hand-held Analyzer
UL-1009	SD Memory Card for Hand-held Analyzers
UL-1013	CF Memory Card for Hand-held Analyzers
UA-1654	5 Extra Styli

INTERFACING

Type 7815	Noise Explorer – data viewing software
Type 7821	Evaluator Light – data viewing and calculation software
Type 7825	Protector – software for calculation of Personal Noise Exposure

SERVICE PRODUCTS

2250-L-EW1	Extended Warranty, one year extension
2250-L-MU1	Upgrade of 2250 Light to Type 2250, performed at headquarters

Brüel & Kjær 



PRODUCT DATA

Outdoor Microphone Unit — Type 4198 Outdoor Microphone Kit — UA-1404

Type 4198 is a weather-proof microphone and preamplifier assembly that meets IEC 61672 class 1 and ANSI S1.4 Type 2 specifications. Use it in any situation where you must make precise outdoor sound measurements.

Type 4198 is even suitable for semi-permanent, unsupervised outdoor installation.

Outdoor Microphone Kit UA-1404 includes all of the protective features of Type 4198, but without the microphone and preamplifier. It enables you to weather-proof your Falcon™ range microphones and preamplifiers. It can also protect the microphones and preamplifiers for Sound Level Meters Types 2236, 2250 and 2260. All recommended combinations fulfil IEC 61672 class 1 and ANSI S1.4 Type 2 specifications (see configuration diagram, Fig. 7).

Both the unit and the kit enable you to take measurements that are protected against the effects of wind, rain, and perching birds.



USES AND FEATURES

USES

- IEC 61672 class 1 compliant outdoor sound measurements in all weather conditions
- Unattended, semi-permanent outdoor installations
- Noise control
- Complaint investigations
- Research

FEATURES

- Protected against the effects of wind, rain, and perching birds
- Easy acoustic calibration

- Detailed free-field corrections on mini CD to obtain flat response in all sound fields
- Falcon™ range product with a 3-year guarantee
- UA-1404 usable with existing Falcon™ range microphones and preamplifiers

TYPE 4198 ALSO FEATURES

- Built-in Type 1 microphone and preamplifier
- Wide dynamic range: 15.2 dB(A) to 146 dB
- Remote calibration monitoring using CIC
- Individual microphone calibration charts
- Easy connection to standard measurement microphone equipment

Effective Protection in Outdoor Environments

Both Outdoor Microphone Unit Type 4198 and Outdoor Microphone Kit UA-1404 use the same protective assembly.

Effective Wind Protection

The windscreen reduces wind noise by approximately 15 dB for wind speeds up to 120 km/h. It is made of a specially prepared porous polyurethane foam, which is resistant to corrosive atmospheres and immune to moisture.

Effective Rain Protection

A rain cover protects the microphone from moisture. The cover surrounds the microphone cartridge inside the wind screen (see Fig. 5). It is specially designed to minimise its effect on the frequency and directional characteristics of the assembly.

Chemical resistant

All essential components are made of stainless steel to withstand tough environments.

Support and Protection

The windscreen is supported by three stainless steel rods that also protrude as rubber-capped spikes, which prevent birds from perching on the microphone. Each of the bird spikes is capped with soft rubber to make them easier to see and to help prevent eye injuries (see Fig. 5).

Fig. 1
The wind and rain cover can be removed easily, but not accidentally. This exposes the microphone for easy calibration

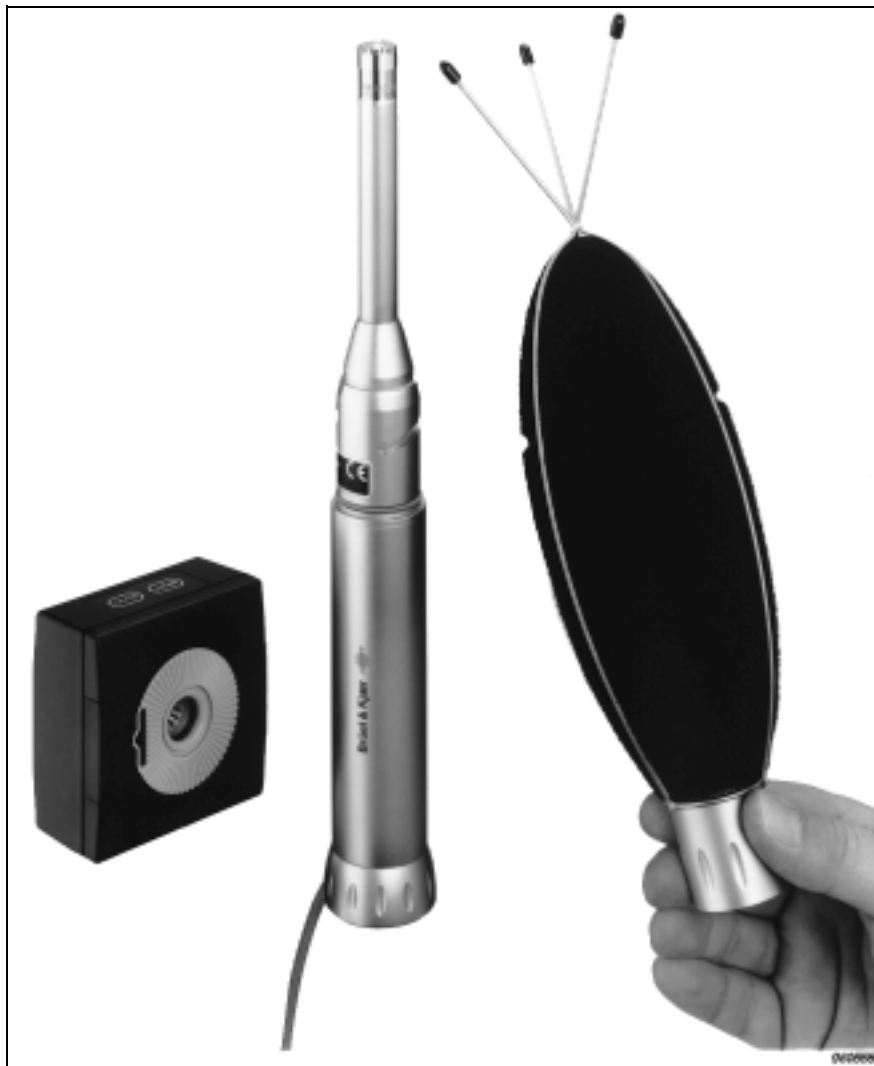

Long Lasting

The unit provides excellent long-term mechanical stability. Should the frame become bent or the foam worn-out, replacements are available.

Easy Acoustic Calibration

Many all-weather microphone systems provide durability at the expense of microphone accessibility, which makes acoustical calibration difficult. With Type 4198 and UA-1404, the windscreen and rain cover assembly can easily be removed, thus exposing the microphone for easy acoustical calibration (see Fig. 5).

Fig. 2
Frequency response of Outdoor Microphone Unit Type 4198. IEC 61672 class 1 tolerances are shown above and below the response curve

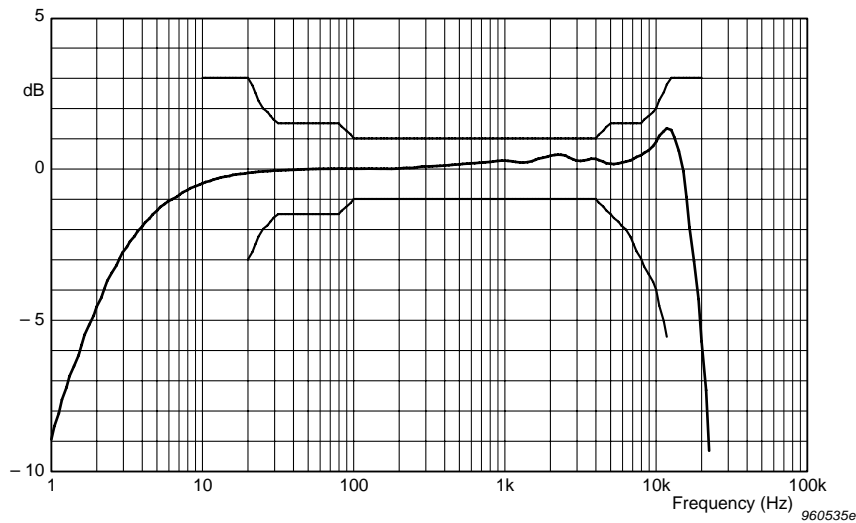

Fig. 3
Change in frequency response of Type 4188 microphone with Outdoor Microphone Kit UA-1404 (including the effect of the replacement grid)

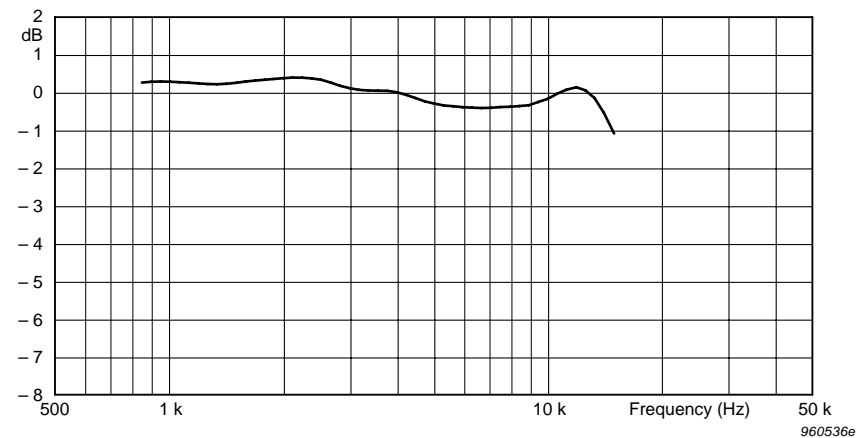
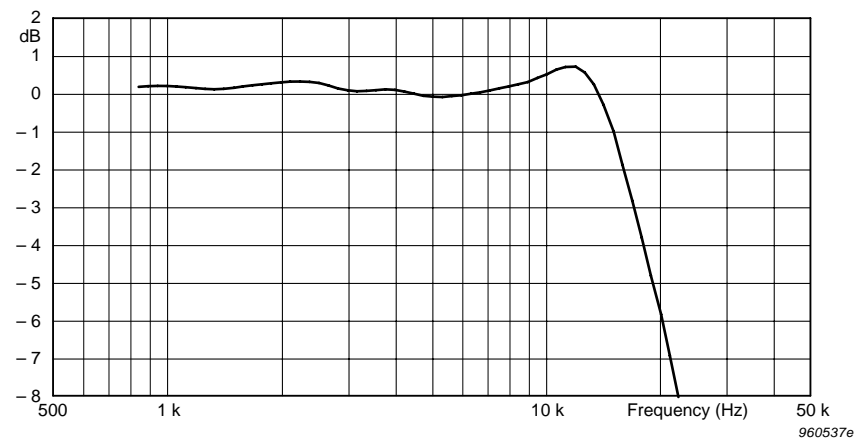
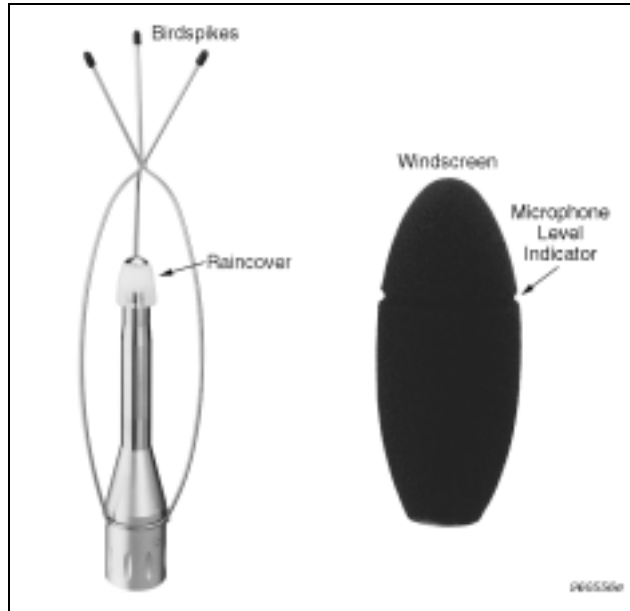

Fig. 4
Change in frequency response of Types 4189 and 4190 microphones with Outdoor Microphone Kit UA-1404 (including the effect of the replacement grid)



Unattended Outdoor Monitoring

Fig. 5
The weather protection components of Type 4198 and UA-1404



All of the features of Type 4198 and UA-1404 combine to create an assembly that can safely be installed for semi-permanent outdoor sound measurement. The assembly will maintain consistent performance even when left unattended in bad weather for several weeks.

Precise Microphone Placement

The height of the microphone inside the windscreen is clearly marked by the groove moulded into the screen (see Fig. 5).

Type 4198 — The Complete Outdoor Microphone

Precision Components

Outdoor Microphone Type 4198 includes the following components:

- Falcon Range Prepolarized Free-field 1/2" Microphone Type 4189
- Falcon Range 1/2" Microphone Preamplifier Type 2669-C
- Outdoor Microphone Kit UA-1404
- 10 meter extension cable AO-0414-D-100

Type 1 Microphone Cartridge

The Type 4198 includes a Falcon Range Prepolarized Free-field 1/2" Microphone Type 4189. Type 4189 is a rugged microphone that ensures high stability under a variety of conditions. Its stainless steel alloy diaphragm withstands even polluted industrial environments.

During manufacturing, each microphone is artificially aged at a high temperature to ensure good long-term stability.

Type 1 Preamplifier

Falcon Range Preamplifier Type 2669-C operates over a wide range of temperatures, humidity levels and other environmental conditions. Type 2669-C is especially well-suited for outdoor monitoring because of its ability to work with very long cables. It provides an extremely wide frequency and dynamic range with low noise.

Save Time and Expense with CIC

Brüel & Kjær's patented Charge Injection Calibration (CIC) facility is built into the preamplifier. It enables you to remotely monitor the microphone system for impedance changes, which can indicate a need for recalibration or repair. This will extend the period between acoustical

calibrations, thus saving you time and expense. For more information about CIC, see the Brüel & Kjær Microphone Handbook (BA 5105).

Individual Calibration

Each unit comes with individual calibration charts and a mini CD containing detailed free-field corrections to the actuator response. The corrections are supplied as comma separated ASCII text files.

Obtain Flat Response in All Fields

The information contained on the mini CD enables you to make extremely precise free-field measurements. When you are performing detailed frequency analysis, this information will enable you to adjust your readings to obtain a flat microphone response in any sound field.

Use Your Existing Equipment Outdoors with UA-1404

Outdoor Microphone Kit UA-1404 includes all of the weather protection equipment of Outdoor Microphone Type 4198 (windscreen, rain cover, bird spikes, and stainless steel enclosure). The kit is compatible with the following Brüel & Kjær equipment:

- Falcon Range Microphone Types 4188, 4189, and 4190
- Falcon Range Preamplifier Types 2671 and 2669-B/L/C
- Microphone and preamplifier from Hand-held Analyzer Type 2250
- Microphone and preamplifier from Sound Analyzer Type 2260
- Microphone and preamplifier from Sound Level Meter Type 2236 (see “Type 2236 Considerations” below)

The kit will enable you to use your existing equipment to make outdoor measurements, even unattended or in bad weather.

The kit includes two stainless steel 1/2" replacement microphone grids, which are required to obtain the correct frequency response. One is for use with microphone Type 4188 and the other for Types 4189 and 4190. They also help protect your microphone cartridge from corrosion.

Obtain Flat Response in All Fields

Like Type 4198, UA-1404 includes a disc containing detailed free-field corrections for each microphone recommended for use with the kit. See the Type 4198 section above for more information.

Type 2236 Considerations

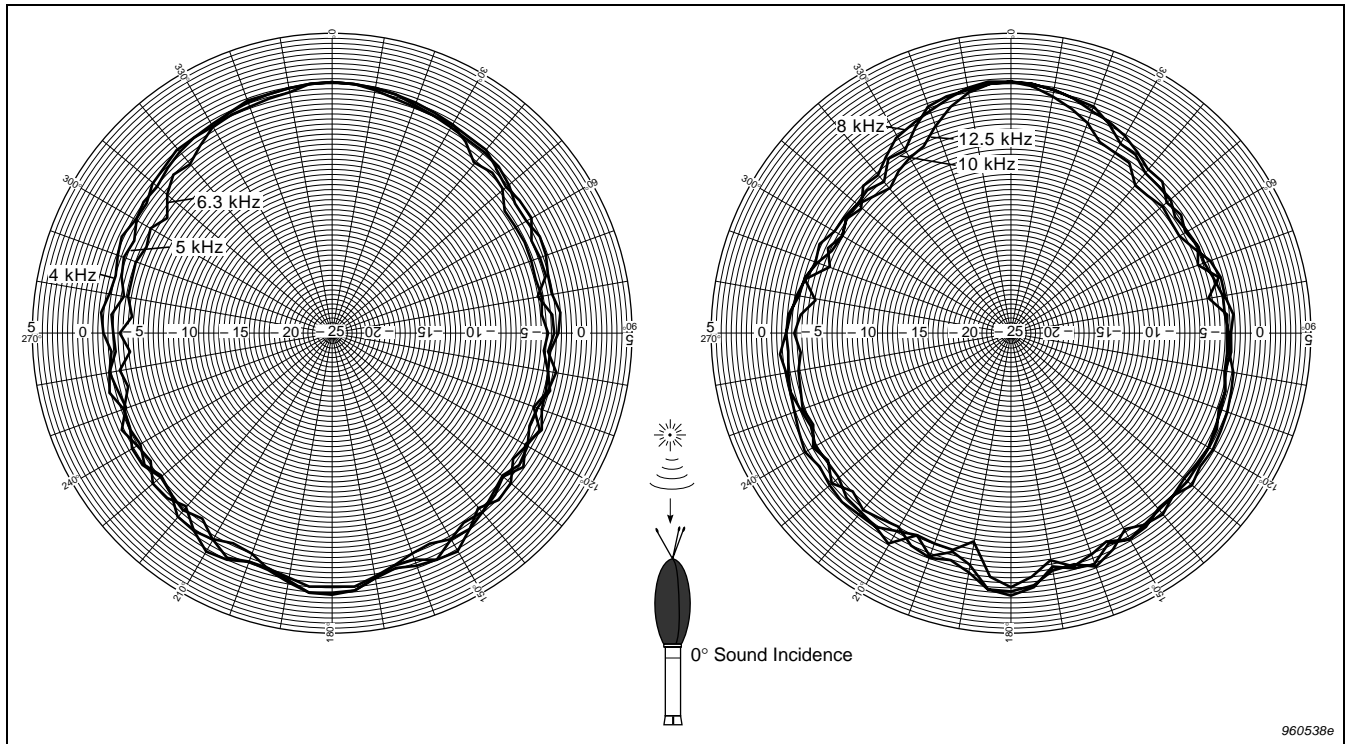

UA-1404 extends the distance between the microphone and the preamplifier. This causes a 2 dB loss in the sound signal, which may invalidate your instrument's calibration. You must therefore check the chart that came with your Type 4188 microphone. Make sure the sensitivity is between –30.5 dB and –28 dB before using UA-1404 with your instrument. If the sensitivity lies below –30.5 dB, then you must purchase a more sensitive Type 4188 microphone to use with UA-1404.

Fig. 6 Directional characteristics for both Type 4198 and UA-1404



960538e

Compliance with Standards

 	CE-mark indicates compliance with: EMC Directive and Low Voltage Directive. C-Tick mark indicates compliance with the EMC requirements of Australia and New Zealand.
Safety	EN/IEC 61010-1: Safety requirements for electrical equipment for measurement, control and laboratory use. UL 61010-1: Standard for Safety – Electrical measuring and test equipment.
EMC Immunity	EN/IEC 61000-6-1: Generic standards – Immunity for residential, commercial and light industrial environments. EN/IEC 61000-6-2: Generic standards – Immunity for industrial environments. Note: The above is guaranteed only with extension cables AO-0414, AO-0415 and AO-0416.
Temperature	IEC 60068-2-1 & IEC 60068-2-2: Environmental Testing. Cold and Dry Heat. Operating Temperature: -20 to +60°C (-4 to +140°F), (150°C (302°F) with increase in noise) Storage Temperature: -25 to +70°C (-13 to +158°F)
Humidity	IEC 60068-2-78: Damp Heat: 95% RH (non-condensing at 40°C (104°F))
Mechanical	Non-operating: IEC 60068-2-6: Vibration: 0.3 mm, 20 m/s ² , 10–500 Hz IEC 60068-2-27: Shock: 1000 m/s ² IEC 60068-2-29: Bump: 400 bumps at 400 m/s ²
Reliability	MI-HDBK 217F, GB (Part-Stress): MTBF >40000 hours (max. 2.5% errors/1000 h)

Specifications – Outdoor Microphone Unit Type 4198

COMPLIANCE WITH STANDARDS

The unit meets IEC 61672 class 1 and ANSI S1.4 Type 2. It also complies with the EMC Directive and Low Voltage Directive (see CE box, below).

MICROPHONE CARTRIDGE

Falcon Range Prepolarized Free-field 1/2" Microphone Type 4189^a

PREAMPLIFIER

Falcon Range 1/2" Microphone Preamplifier Type 2669-C^b

a. See separate product data sheet (BP 1380) or Microphone Handbook (BA 5105) for complete specifications for this microphone

SENSITIVITY (250 Hz)

-26 ±2 dB re 1V/Pa, 50 mV/Pa
 (individually calibrated)

FREQUENCY RESPONSE

0° incidence free-field response
 ±1 dB 10 Hz to 8 kHz
 ±2 dB 6.3 Hz to 16 kHz
 In accordance with IEC 61672651 class 1

b. See separate product data sheet (BP 1422) for complete specifications for this preamplifier

LOWER LIMITING FREQUENCY (-3 dB)

2 Hz to 4 Hz

DIAPHRAGM RESONANCE FREQUENCY

14 kHz (90° phase shift)

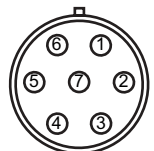
EQUIVALENT AIR VOLUME (101.3 kPa)45 mm³**CALIBRATOR LOAD VOLUME (250Hz)**260 mm³**PIN CONNECTIONS**

Cable's output plug seen from outside

Pin	Signal
1	Calibration input
2	Signal ground
3	Pol. voltage
4	Signal output
5	TEDS data wire
6	Power supply negative & ground
7	Power supply negative & ground
Casing	Connected to instrument chassis

960517/2

PISTONPHONE TYPE 4228 CORRECTION

(with DP 0776): 0.00 dB

NOISE LEVEL

15.2 dB (A), 17.4 dB (Lin.)

UPPER LIMIT OF DYNAMIC RANGE

3% distortion: >146 dB SPL

MAXIMUM SOUND PRESSURE LEVEL

158 dB (Peak)

POWER SUPPLY, DUAL

±14 V to ±60 V

POWER SUPPLY, SINGLE

28 V to 120 V

OUTPUT DC OFFSET

≈ 1 V for dual supply, or ≈ 1/2 the voltage of a single supply

POLARIZATION VOLTAGE (EXTERNAL)

0 V

Environmental Specifications**INFLUENCE OF HUMIDITY**

< 0.1 dB at up to 95% RH (non-condensing) and 40°C

WIND NOISE ATTENUATION

> 15 dB (for wind speed up to 120 km/h)

TEMPERATURE COEFFICIENT (250 Hz)

- 0.001 dB/°C, typical (for the range -10° to +50° C (14 to 122° F))

PRESSURE COEFFICIENT (250 Hz)

- 0.010 dB/kPa

VIBRATION SENSITIVITY (<1000 Hz)62.5 dB equivalent SPL for 1 m/s² axial acceleration**MAGNETIC FIELD SENSITIVITY**

6 dB SPL for 80 A/m, 50 Hz field

ESTIMATE LONG-TERM STABILITY

> 1000 years/dB (dry air at 20°C (68°F))

> 40 years/dB (air at 20°C (68°F), 90% RH)

> 1 year/dB (air at 50°C (122°F), 90% RH)

RAIN

Rainproof to IP 44

DURABILITY**Measurement in large city environment before cleaning and drying:** > 4 weeks**Measurement in large city environment before microphone system overhaul:** > 4 months**Physical Characteristics****DIMENSIONS****Height:** 412 mm (16.2")**Diameter (at widest point):** 72 mm (2.8")**WEIGHT**

580 grams (1.3 lb.)

Specifications – Outdoor Microphone Kit UA-1404**Compatible Sound Meters****TYPE 2236 SOUND LEVEL METER**

The Type 4188 microphone (included with Type 2236) must have a sensitivity between -30.5 dB and -28 dB (see "Type 2236 Considerations," above). Preamplifier ZC-0027 (included with Type 2236) is compatible as shipped.

TYPE 2260 SOUND ANALYZER

Preamplifier ZC-0026 and Microphone Type 4189 (both included with the Type 2260) are compatible as shipped.

TYPE 2250 SOUND ANALYZER

Preamplifier ZC-0032 and Microphone Type 4189 (both included with the Type 2250) are compatible as shipped.

Compatible Microphones**TYPES 4188, 4189 AND 4190**

All microphones require a stainless steel replacement grid to meet the specified frequency characteristics. The grid also provides extra protection from corrosion. Two replacement grids are included with UA-1404: one for Microphone Type 4188, the other for Types 4189 and 4190.

Compatible Preamplifiers**TYPE 2669-B/L/C**

Compatible as shipped

TYPE 2671

Compatible as shipped

Standards**ALL RECOMMENDED CONFIGURATIONS**

IEC 61672 class 1 and ANSI S1.4 Type 2
(See configuration chart, Fig. 7)

Windscreen**WIND NOISE ATTENUATION**

> 15 dB (for wind speed up to 120 km/h)

MATERIAL

Windscreen: Open-pored polyurethane foam

Spikes: Stainless steel

Environmental Specifications**OPERATING TEMPERATURE RANGE**

-30 to +150°C (-22 to +302°F)

The actual range will be determined by the preamplifier used.

RAIN

Rainproof to IP 44

DURABILITY

Measurement in large city environment before cleaning and drying:
>4 weeks

Measurement in large city environment before microphone system
overhaul:>4 months

Physical Characteristics

DIMENSIONS

Height: 412 mm (16.2")

Diameter (at widest point): 72 mm (2.8")

WEIGHT

540 grams (1.3 lb.) (empty)

Ordering Information

Type 4198 Includes the following accessories:

Type 4189 Falcon Range Prepolarized Free-field 1/2" Microphone

Type 2669-C Falcon Range 1/2" Microphone Preamplifier
UA-1404 Outdoor Microphone Kit

AO-0414-D-100 10 m (32.8 ft.) LEMO 1B to LEMO 1B Cable

Spare Parts

DS-0934 Replacement windscreen

UC-5360 Replacement Bird Spikes

Optional Accessories

ZG-0350 LEMO 1B to 7-pin Brüel & Kjær adaptor

UA-0587 Tripod

BNC TO BNC COAXIAL CABLES

For UA-1404 with Type 2671 Preamplifiers

AO-0426-D-100 10 m Single Screened (32.8 ft.)

AO-0087-D-100 10 m Double Screened (32.8 ft.)

Other cable lengths on request.

LEMO 1B TO LEMO 1B CABLES

For Type 4198 and UA-1404 with Preamplifier Type 2669-C

AO-0414-D-030 3 m (9.8 ft.)

Other cable lengths on request.

AR-0014 Flat Cable

LEMO 0B TO LEMO 1B

For UA-1404 with Preamplifiers Type 2669-B/L without the included cable.

AO-0419-D-030 3 m (9.8 ft.) (included with Preamplifier Type 2669-L)

Other cable lengths on request.

LEMO 0B TO BRÜEL & KJÆR CONNECTER

For UA-1404 with Preamplifiers Type 2669-B/L without the included cable.

AO-0428-D-030 3 m (9.8 ft.) (included with Preamplifier Type 2669-B)

Other cable lengths on request.

BRÜEL & KJÆR EXTENSION CABLES

For UA-1404 with Preamplifier Type 2669-B with the included cable (AO-0428).

AO-0027-D-030 3 m (9.8 ft.) Extension Cable

AO-0027-D-100 10 m (32.8 ft.) Extension Cable

AO-0027-M-030 30 m (98.4 ft.) Extension Cable

FOR TYPE 2250 OR 2260 SOUND ANALYZER

AO-0441-D-030 3 m Extension Cable (9.8 ft.)

AO-0441-D-100 10 m Extension Cable (32.8 ft.)

Fig. 7 Outdoor Microphone Kit UA-1404 schematic diagram including connections and cables required for use with compatible microphones and preamplifiers

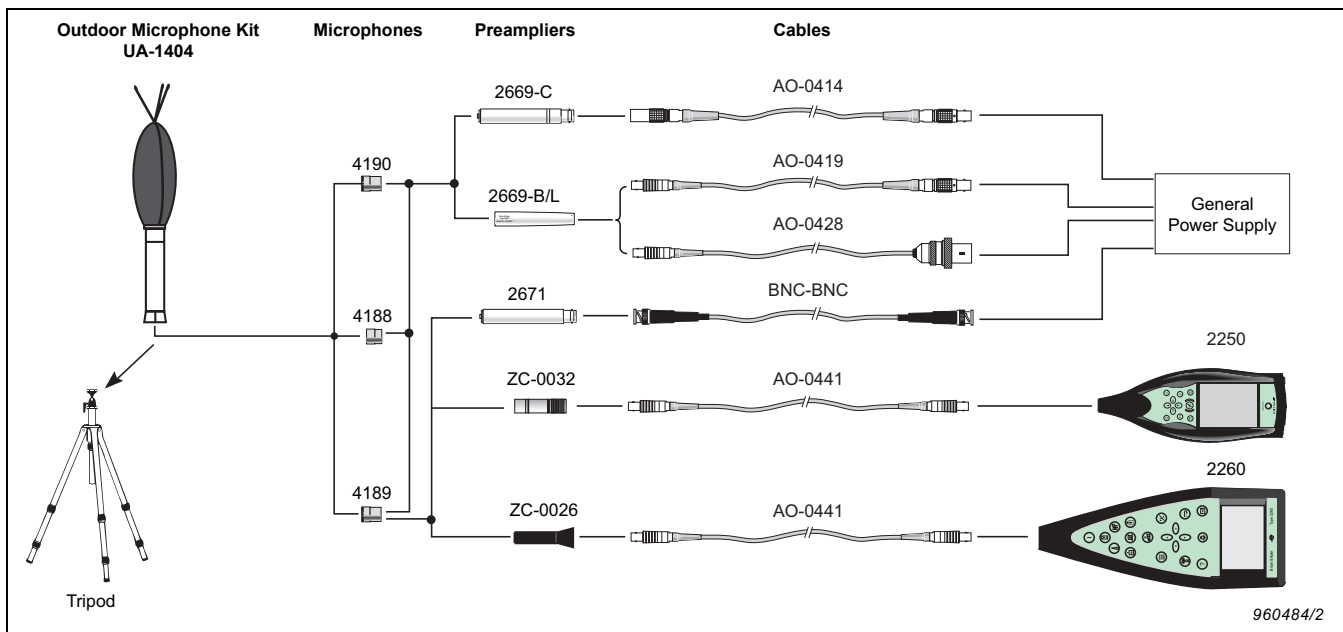

Brüel & Kjær reserves the right to change specifications and accessories without notice

HEADQUARTERS: DK-2850 Nærum · Denmark · Telephone: +45 4580 0500 · Fax: +45 4580 1405
www.bksv.com · info@bksv.com

Australia (+61) 2 9889-8888 · Austria (+43) 1 865 74 00 · Brazil (+55) 11 5188-8161
Canada (+1) 514 695-8225 · China (+86) 10 680 29906 · Czech Republic (+420) 2 6702 1100
Finland (+358) 9-521 300 · France (+33) 1 69 90 71 00 · Germany (+49) 421 17 87 0
Hong Kong (+852) 2548 7486 · Hungary (+36) 1 215 83 05 · Ireland (+353) 1 807 4083
Italy (+39) 0257 68061 · Japan (+81) 3 5715 1612 · Republic of Korea (+82) 2 3473 0605
Netherlands (+31) 318 55 9290 · Norway (+47) 66 77 11 55 · Poland (+48) 22 816 75 56
Portugal (+351) 21 41 69 040 · Singapore (+65) 6377 4512 · Slovak Republic (+421) 2 5443 0701
Spain (+34) 91 659 0820 · Sweden (+46) 33 225 622 · Switzerland (+41) 44 880 7035
Taiwan (+886) 2 2502 7255 · United Kingdom (+44) 14 38 739 000 · USA (+1) 800 332 2040

Local representatives and service organisations worldwide

Brüel & Kjær 



Chapter 7

Connection to PC or Mobile Phone

7.1 Introduction

You can connect to your analyzer from a PC or mobile phone in a number of different ways using a wide range of different connection types:

- Use Utility Software for Hand-held Analyzers, BZ-5503 for full control of the analyzer – see section 7.2
- Use an Internet Browser for On-line display and control of the analyzer - see section 7.4

Three different methods are available for connecting to the Analyzer:

- USB: BZ-5503 connects to the analyzer through a USB cable
- Modem: BZ-5503 connects to the analyzer through modem (BZ-5503 uses two modems - one modem connected to the PC for dialling up, and another modem connected to the analyzer)
- Network: The analyzer is connected to a network (local or internet). BZ-5503 or an Internet Browser will then be able to connect to the analyzer through TCP/IP using the analyzer's (global) IP address

In addition to connecting to the analyzer, the analyzer itself can notify you by SMS, or E-mail, based on various conditions – see section 8.4.

Table 7.1 gives you an overview of the different connection possibilities including links to relevant chapters with more details.

Note: The on-line help for BZ-5503 contains additional information on how to connect an instrument using the different connection types.

Table 7.1 Connection overview

Connect from	Connection Type	Settings in Preferences	Available Notifications
BZ-5503	USB	Modem = <i>Disabled</i> see section 8.2.	N.A.
BZ-5503	Modem <i>analogue</i> (PSTN)	Modem = <i>Auto Answer</i> see section 8.2.	N.A.
BZ-5503	Modem GSM	Modem = <i>Auto Answer</i> . see section 8.2.	SMS ^a see section 8.4
BZ-5503 Mode	m GPRS/3G	Modem = <i>Auto Answer</i> . see section 8.2.	SMS ^a see section 8.4
BZ-5503 or In ternet Browser <i>Mobile Phone with Internet Browser</i>	Network GPRS/3G <i>modem</i>	Modem = <i>GPRS/3G Dialup</i> Settings in Dialup Networking. Network Settings. Possibly settings in DynDNS. see section 8.2 and 8.3.	E-mail see section 8.4
BZ-5503 or In ternet Browser <i>Mobile Phone with Internet Browser</i>	Network <i>Ethernet cable</i>	Modem = <i>Disabled</i> Possibly settings in DynDNS. Network Settings. see section 8.2 and 8.3.	E-mail see section 8.4
BZ-5503 or In ternet Browser <i>Mobile Phone with Internet Browser</i>	Network CF WLAN	Modem = <i>Disabled</i> Possibly settings in DynDNS. Network Settings. Settings in Wireless Network. see section 8.2 and 8.3.	E-mail see section 8.4
BZ-5503 or In ternet Browser <i>Mobile Phone with Internet Browser</i>	Network <i>DSL Modem/ Router</i>	Modem = <i>Disabled</i> Possibly settings in DynDNS. Network Settings. see section 8.2 and 8.3.	E-mail see section 8.4

a. SMS is also possible for the setting Modem = *Disabled*.

7.2 Transferring Measurement Data to Your PC

Utility Software for Hand-held Analyzers BZ-5503 is used for communication between your PC and the analyzer. Connect the analyzer to your PC using the supplied USB Cable AO-1476, using a modem connection, or through a LAN connection (see Chapter 8).

Use this software to:

- Transfer measurement data and templates from the analyzer to your PC, and vice versa
- View data
- Organise data on the analyzer

- Upgrade software on the analyzer
- Install software licenses on the analyzer

Using this software, measurements on the analyzer can be controlled from your PC and displayed on-line, using the same user interface on the PC as on the analyzer.

Data transferred to the PC are organised in Archives.

View the measurement data in the Archives or edit the project templates.

Data in the archives can be exported to:

- Noise Explorer Type 7815
- Evaluator Type 7820
- Protector Type 7825
- Predictor Type 7810
- Lima Type 7812
- Acoustic Determinator Type 7816
- Microsoft® Excel® for further post-processing and reporting

7.3 Post-processing and Reporting

The software modules are further enhanced by Brüel & Kjær's post-processing software suite, including Utility Software for Hand-held Analyzers BZ-5503 for data transfer, setup and remote display (included with your analyzer), Noise Explorer Type 7815 for viewing data, Evaluator Type 7820 for assessing environmental noise, Protector Type 7825 for assessing workplace noise.

For further information, please refer to the on-line help included with the relevant PC Software. This software is supplied on the Environmental Software DVD (BZ-5298), which is included with your the analyzer.

7.4 Internet Browser for On-line Display and Control of the Analyzer

When the analyzer is connected to a network (see Fig.7.1) you can connect to the analyzer from a PC or mobile phone using an Internet Browser supporting Java scripts.

Analyzer settings:

You access preferences by tapping on the Main Menu icon  and selecting **Preferences** from the list of options (the screen shown in Fig.8.1 will appear).

Tap on *Web Server Settings*, or select the plus icon  next to *Web Server Settings* and set the *Web Server* Parameters to *Enabled*. Define sets of Usernames and Passwords:

- one set for guest use (view only)
- one set for administrator use of the instrument (view and full control)



APPENDIX B

SCHEMATIC DRAWING OF THE MONITORING EQUIPMENTS

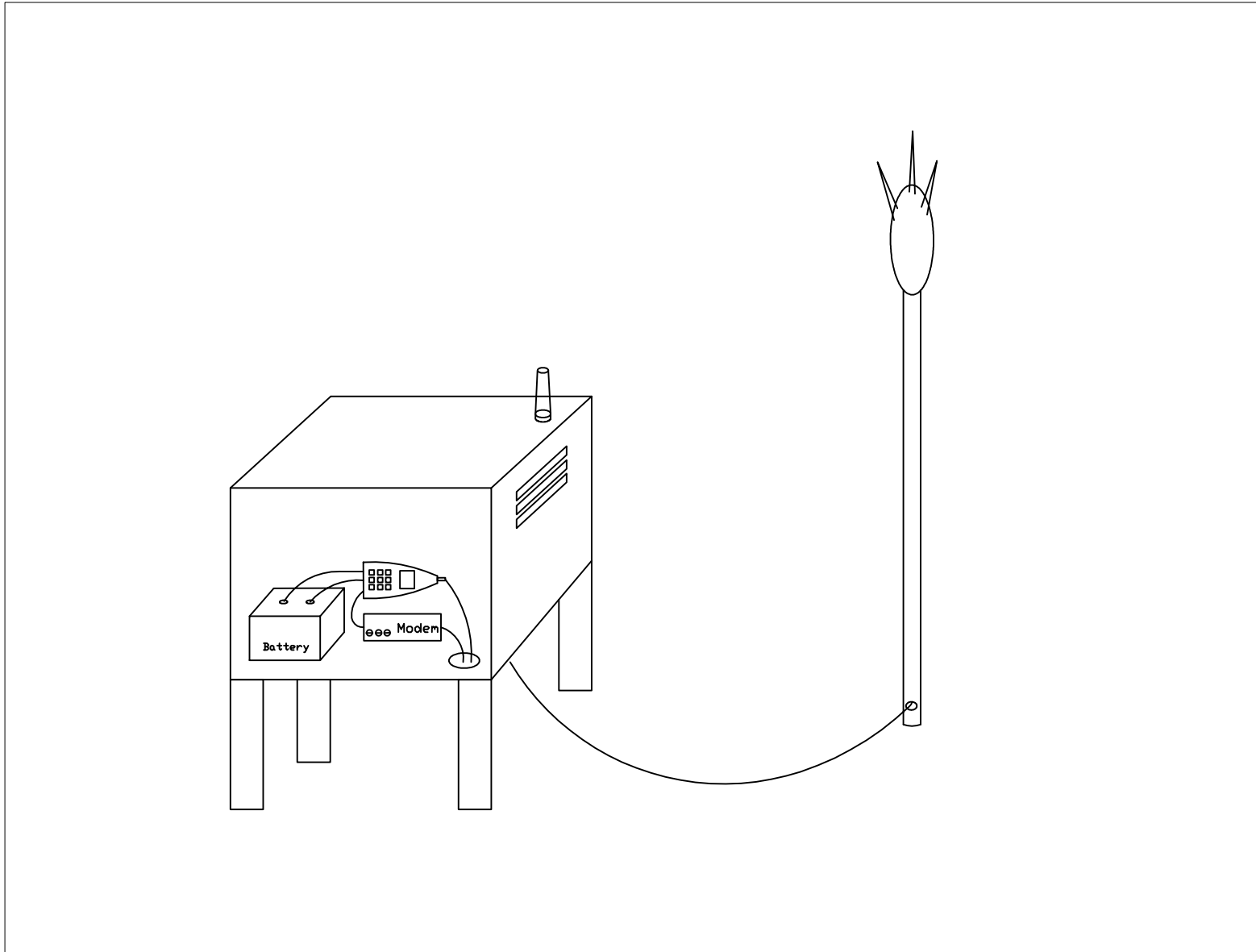

Schematic Drawing of the Monitoring Equipments

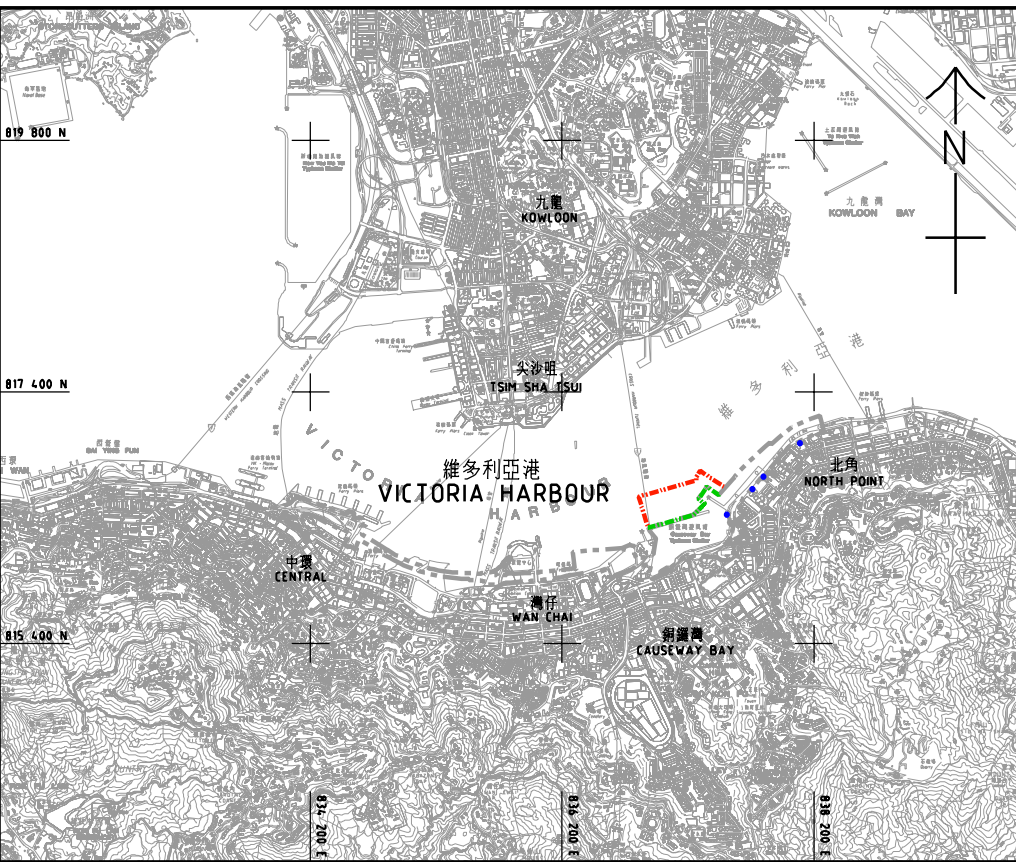
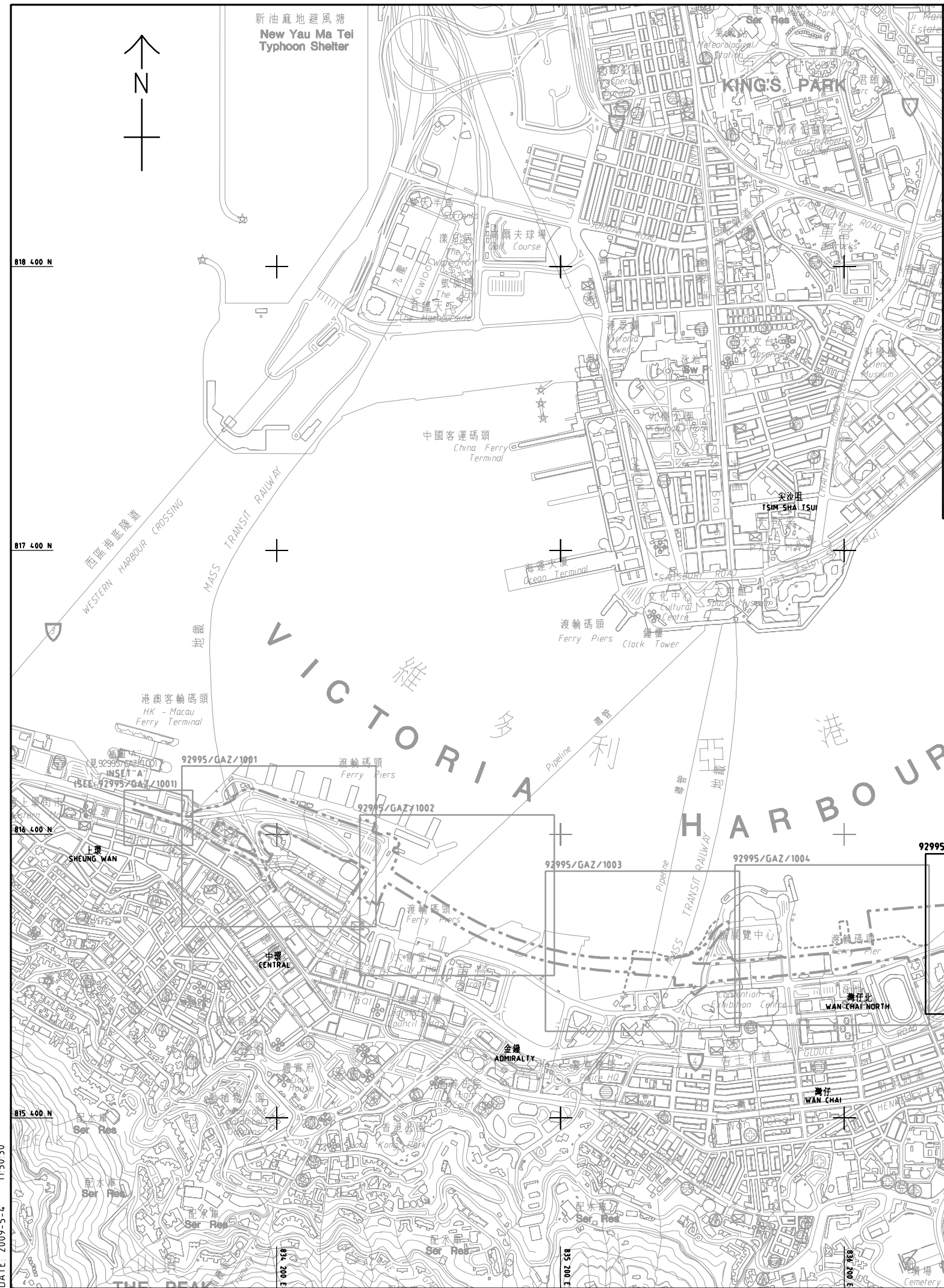

LOCATION PLAN 位置圖
SCALE 1 : 30000 比例 1 : 30000

- 圖例: LEGEND:
- 原有部分 ORIGINAL
- 施工區界限 LIMIT OF WORKS AREA
 - 灣仔發展計劃第II期填海範圍(有關填海工程將根據前濱及海床(填海工程)條例(第127章)另行刊憲)(只供指示用途) RECLAMATION EXTENT FOR WAN CHAI DEVELOPMENT PHASE II (TO BE GAZETTED UNDER FORESHORE AND SEA-BED (RECLAMATIONS) ORDINANCE (CHAPTER 127) SEPARATELY) (FOR INDICATIVE PURPOSE ONLY)
- 修訂部分 AMENDMENT
- 原有建議的施工區界限將被取消 ORIGINALLY PROPOSED LIMIT OF WORKS AREA TO BE DELETED
 - 修訂後的施工區界限 AMENDED LIMIT OF WORKS AREA
 - PROPOSED REAL-TIME NOISE MONITORING STATION

DATE: 2009-5-4 11:50:30

工程名稱 Project title	
工務計劃項目第6579TH號 中環灣仔繞道和東區走廊連接路 PWP ITEM NO. 6579TH CENTRAL - WAN CHAI BYPASS AND ISLAND EASTERN CORRIDOR LINK	
圖則名稱 Plan title	
根據道路(工程、使用及補償)條例 (第370章)而在憲報公布之圖則 PLAN FOR GAZETTING UNDER ROADS (WORKS, USE AND COMPENSATION) ORDINANCE (CHAPTER 370)	
圖則編號 Plan no.	比例 scale
92995/GAZ/1000A	A1 1 : 8000 A3 1 : 16000
辦事處 Office	
主要工程管理處 Major Works Project Management Office	
路政署 HIGHWAYS DEPARTMENT	

DATE: 2009-5-4 11:51:33

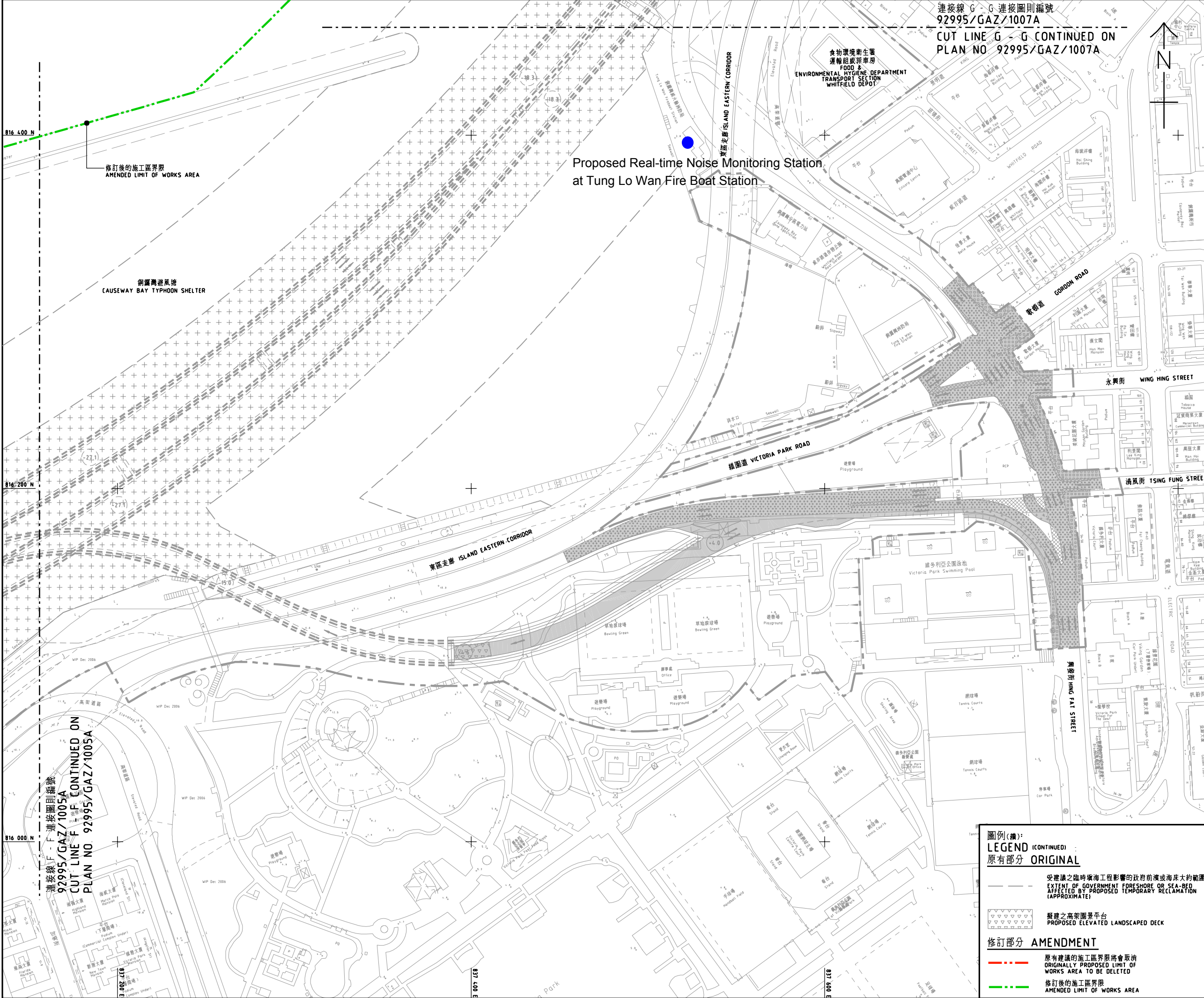

連接線 G - G 連接圖則編號
92995/GAZ/1007A
CUT LINE G - G CONTINUED ON
PLAN NO 92995/GAZ/1007A

Proposed Real-time Noise Monitoring Station
at Tung Lo Wan Fire Boat Station

註釋:
NOTES
1. 除在其他方面指定外, 所有量度以米為單位。
ALL DIMENSIONS ARE IN METRES UNLESS OTHERWISE STATED.
2. 所有水平均為約數, 以米為單位, 並基於香港主水平基準上。
ALL LEVELS ARE APPROXIMATE VALUES AND IN METRES ABOVE HONG KONG PRINCIPAL DATUM.
3. 如有需要, 施工區界限內之現有行車道及行人路之部分路段或會分階段臨時封閉。
SECTIONS OF EXISTING CARRIAGEWAYS AND FOOTPATHS WITHIN LIMIT OF WORKS AREA MAY BE TEMPORARILY CLOSED IN PHASES AS AND WHEN REQUIRED.

圖例:
LEGEND
原有部分 ORIGINAL

	施工區界限 LIMIT OF WORKS AREA
	行車道之行車線 (每一箭頭表示一條行車線) TRAFFIC LANE FOR CARRIAGEWAY (ONE ARROW REPRESENTS ONE LANE)
	露天/於高架圍欄平台下/半開放式隔音罩下道路之建議路面水平(約數) PROPOSED ROAD LEVEL OF OPEN ROAD/ ROAD UNDER ELEVATED LANDSCAPED DECK/ ROAD UNDER NOISE SEMI-ENCLOSURE (APPROXIMATE)
	行車道之建議路面水平(約數) PROPOSED ROAD LEVEL INSIDE ROAD TUNNEL (APPROXIMATE)
	擬建之行人路(連緊急行人通道) PROPOSED FOOTPATH WITH EMERGENCY PEDESTRIAN WALKWAY
	擬建之地面行車道 PROPOSED AT-GRADE CARRIAGEWAY
	擬建之行人路 PROPOSED FOOTPATH
	擬建之高架行車道 PROPOSED ELEVATED CARRIAGEWAY
	擬建之中央分隔帶/安全島 PROPOSED CENTRAL RESERVE/SAFE ISLAND
	擬建之美化市容地帶 PROPOSED AMENITY AREA
	現有政府前濱或海床將予臨時填平, 以便興建行車道 EXISTING GOVERNMENT FORESHORE OR SEA-BED TO BE TEMPORARILY RECLAIMED FOR ROAD TUNNEL CONSTRUCTION
	現有地面行車道將予臨時封閉及重建 EXISTING AT-GRADE CARRIAGEWAY TO BE TEMPORARILY CLOSED AND RECONSTRUCTED
	現有地面行車道將予永久封閉及拆卸 EXISTING AT-GRADE CARRIAGEWAY TO BE PERMANENTLY CLOSED AND DEMOLISHED
	現有高架行車道將予臨時封閉及重建 EXISTING ELEVATED CARRIAGEWAY TO BE TEMPORARILY CLOSED AND RECONSTRUCTED
	現有高架行車道將予永久封閉及拆卸 EXISTING ELEVATED CARRIAGEWAY TO BE PERMANENTLY CLOSED AND DEMOLISHED
	現有行人路將予永久封閉及拆卸 EXISTING FOOTPATH TO BE PERMANENTLY CLOSED AND DEMOLISHED
	現有中央分隔帶/安全島將予重建 EXISTING CENTRAL RESERVE/SAFE ISLAND TO BE RECONSTRUCTED
	現有中央分隔帶/安全島將予拆卸 EXISTING CENTRAL RESERVE/SAFE ISLAND TO BE DEMOLISHED
	現有美化市容地帶將予重建 EXISTING AMENITY AREA TO BE RECONSTRUCTED
	現有美化市容地帶將予拆卸 EXISTING AMENITY AREA TO BE DEMOLISHED
	現有行人路將予臨時封閉及重建 EXISTING FOOTPATH TO BE TEMPORARILY CLOSED AND RECONSTRUCTED
	擬建之行車道大樓範圍 PROPOSED ROAD TUNNEL BUILDING AREA

圖例(續):
LEGEND (CONTINUED)
原有部分 ORIGINAL

	受建議之臨時填海工程影響之政府前濱或海床大約範圍 EXTENT OF GOVERNMENT FORESHORE OR SEA-BED AFFECTED BY PROPOSED TEMPORARY RECLAMATION (APPROXIMATE)
	擬建之高架圍欄平台 PROPOSED ELEVATED LANDSCAPED DECK
	修訂部分 AMENDMENT
	原有建議的施工區界限將予取消 ORIGINALLY PROPOSED LIMIT OF WORKS AREA TO BE DELETED
	修訂後的施工區界限 AMENDED LIMIT OF WORKS AREA

工程名稱 Project title
工務計劃項目第6579TH號
中環及灣仔繞道和東區走廊連接路
PWP ITEM NO. 6579TH
CENTRAL - WAN CHAI BYPASS AND
ISLAND EASTERN CORRIDOR LINK

圖則名稱 Plan title
根據道路(工程、使用及補償)條例
(第370章)而在憲報公布之圖則
PLAN FOR GAZETTING UNDER ROADS
(WORKS, USE AND COMPENSATION)
ORDINANCE (CHAPTER 370)

圖則編號 Plan no. 92995/GAZ/1006A

比例 scale
A1: 1: 1000
A3: 1: 2000

辦事處 Office
主要工程管理處
Major Works Project Management Office

路政署
HIGHWAYS
DEPARTMENT

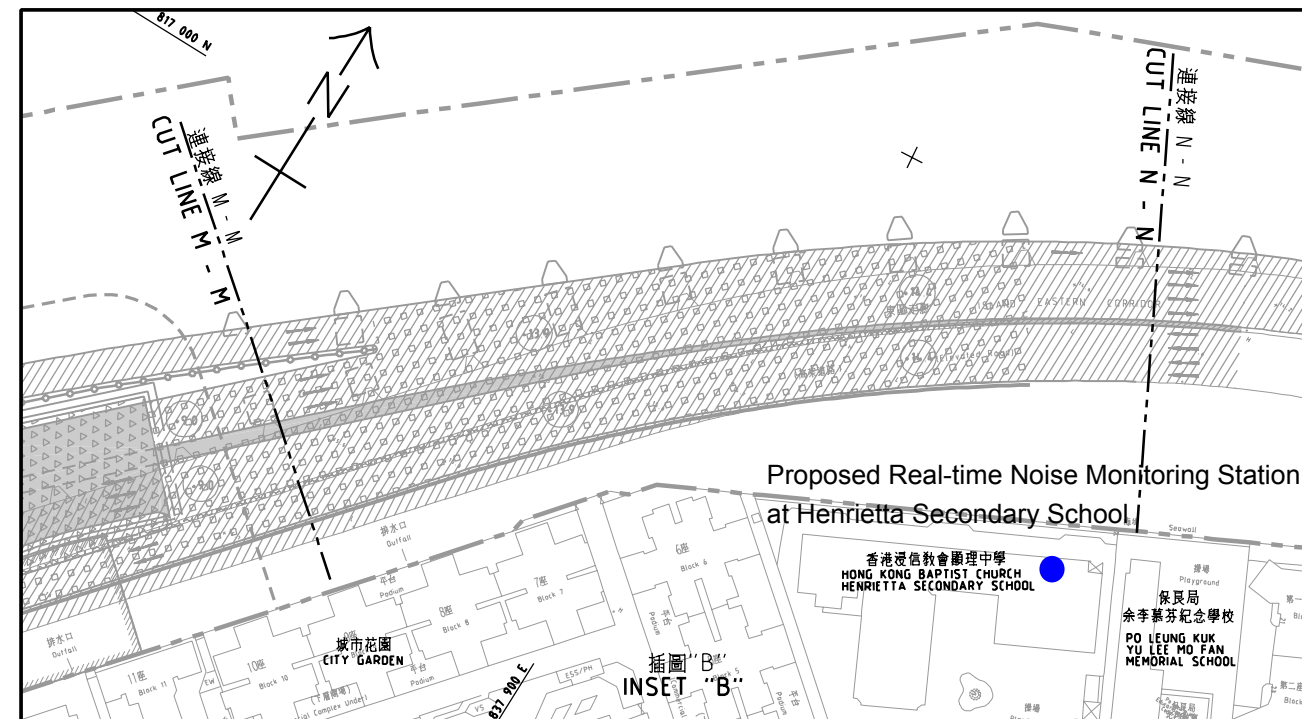

圖例(續): LEGEND (CONTINUED):
原有部分 ORIGINAL

- 灣仔發展計劃第二期填海範圍(有關填海工程將根據填海及海床(填海工程)條例(第127章)另行刊憲)(只供指示用途) RECLAMATION EXTENT FOR WAN CHAI DEVELOPMENT PHASE II (TO BE GAZETTED UNDER FORESHORE AND SEA-BED (RECLAMATIONS) ORDINANCE (CHAPTER 127) SEPARATELY) (FOR INDICATIVE PURPOSE ONLY)
- 受建議之臨時防波堤影響的政府前濱或海床大約範圍 EXTENT OF GOVERNMENT FORESHORE OR SEA-BED AFFECTED BY PROPOSED TEMPORARY BREAKWATER (APPROXIMATE)
- 受建議之臨時填海工程影響的政府前濱或海床大約範圍 EXTENT OF GOVERNMENT FORESHORE OR SEA-BED AFFECTED BY PROPOSED TEMPORARY RECLAMATION (APPROXIMATE)

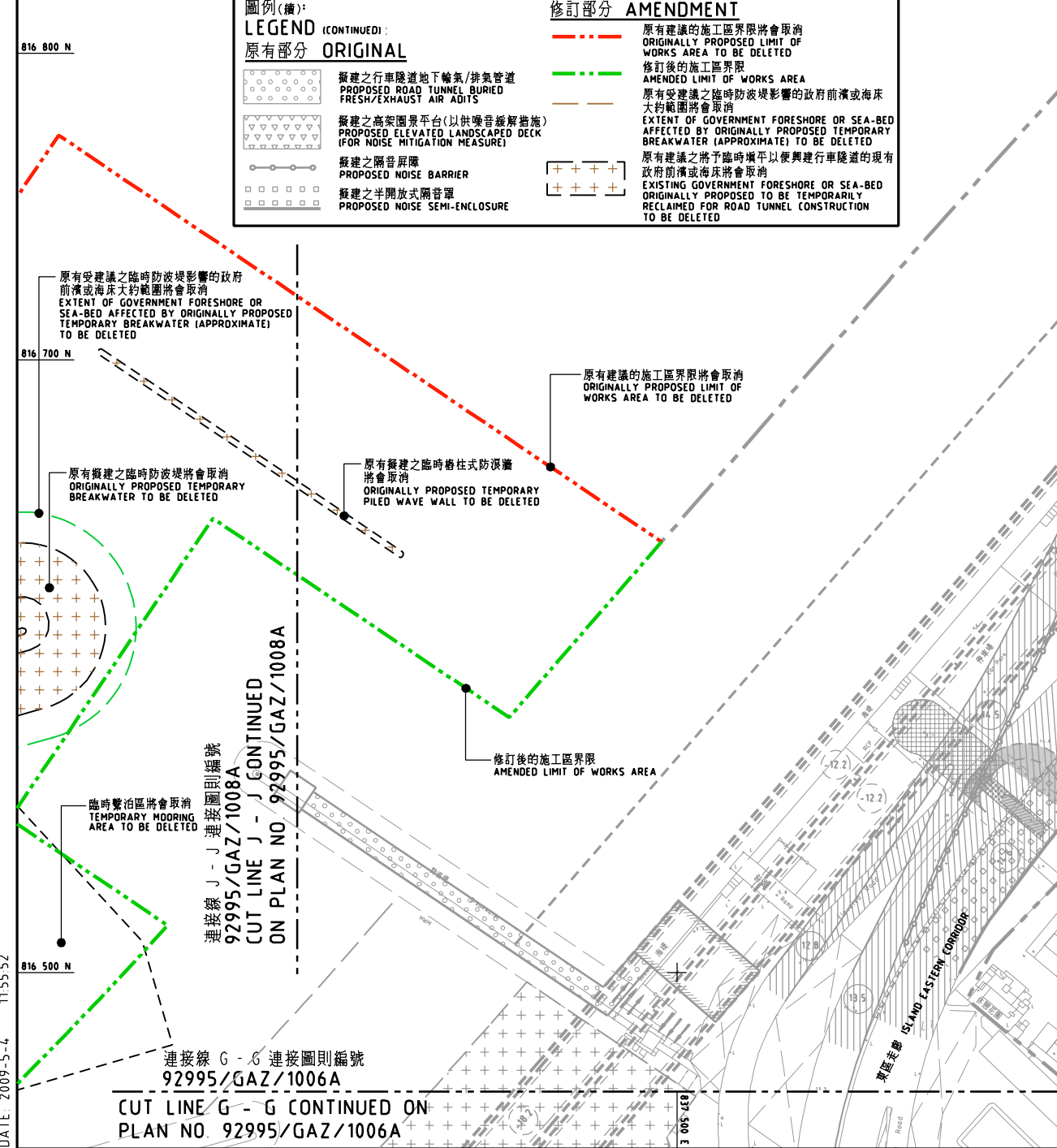

圖例(續): LEGEND (CONTINUED):
原有部分 ORIGINAL

- 擬建之行人車道地下輸氣/排氣管道 PROPOSED ROAD TUNNEL BURIED FRESH/EXHAUST AIR ADITS
- 擬建之高架圍欄平台(以供噪音緩解措施) PROPOSED ELEVATED LANDSCAPED DECK (FOR NOISE MITIGATION MEASURE)
- 擬建之隔音屏障 PROPOSED NOISE BARRIER
- 擬建之半開放式隔音罩 PROPOSED NOISE SEMI-ENCLOSURE

修訂部分 AMENDMENT

- 原有建議的施工區界限將取消 ORIGINALY PROPOSED LIMIT OF WORKS AREA TO BE DELETED
- 修訂後的施工區界限 AMENDED LIMIT OF WORKS AREA
- 原有受建議之臨時防波堤影響的政府前濱或海床大約範圍將取消 EXTENT OF GOVERNMENT FORESHORE OR SEA-BED AFFECTED BY ORIGINALLY PROPOSED TEMPORARY BREAKWATER (APPROXIMATE) TO BE DELETED
- 原有建議之臨時填海工程影響的政府前濱或海床大約範圍將取消 EXTENT OF GOVERNMENT FORESHORE OR SEA-BED AFFECTED BY ORIGINALLY PROPOSED TEMPORARY RECLAMATION (APPROXIMATE) TO BE DELETED
- 原有建議之臨時填海工程影響的政府前濱或海床大約範圍將取消 EXTENT OF GOVERNMENT FORESHORE OR SEA-BED AFFECTED BY ORIGINALLY PROPOSED TEMPORARY RECLAMATION (APPROXIMATE) TO BE DELETED

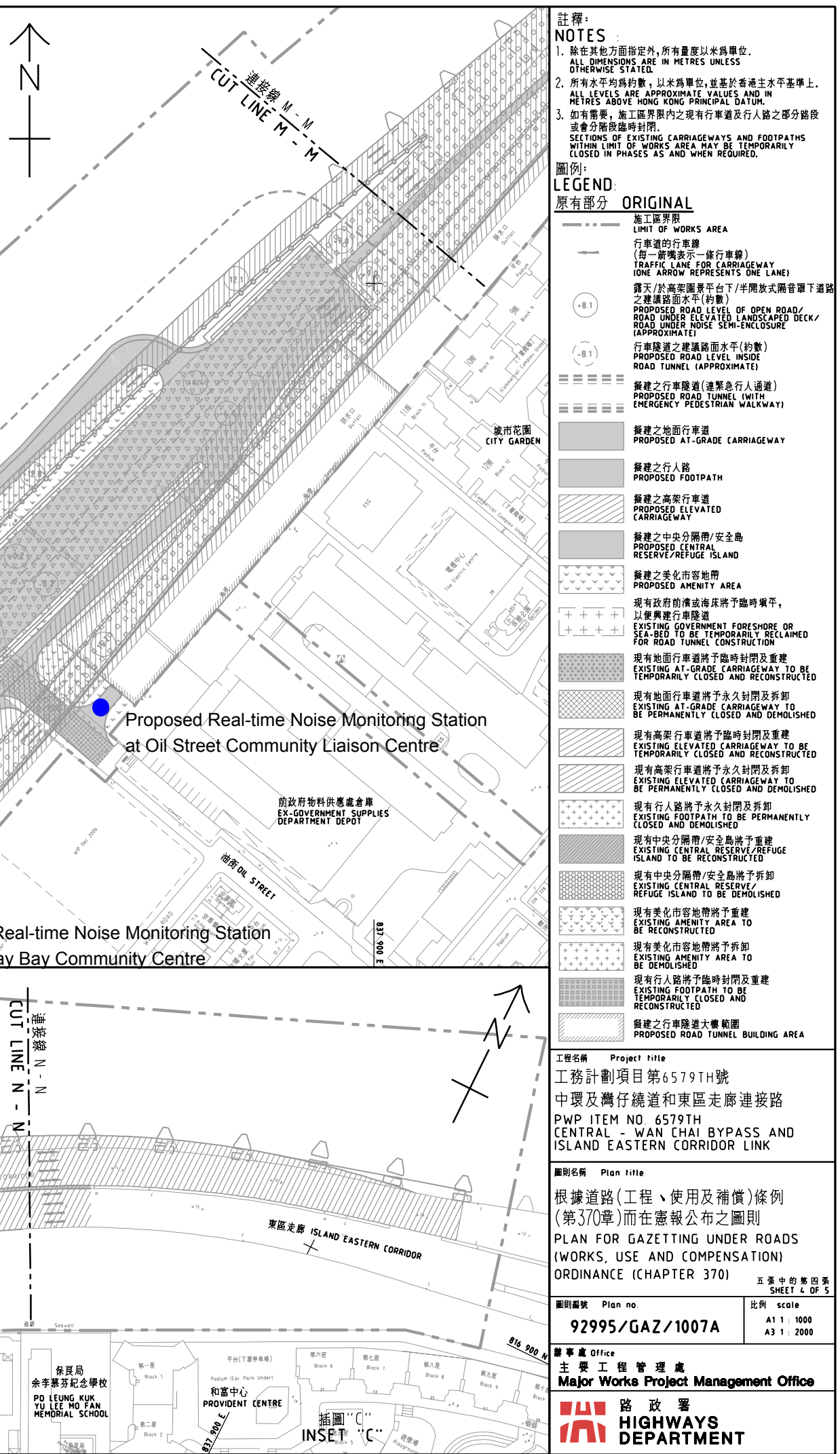

註釋: NOTES

- 除在其他方面指定外,所有量度以米為單位。 ALL DIMENSIONS ARE IN METRES UNLESS OTHERWISE STATED.
- 所有水平均為約數,以米為單位,並基於香港主水平基準上。 ALL LEVELS ARE APPROXIMATE VALUES AND IN METRES ABOVE HONG KONG PRINCIPAL DATUM.
- 如有需要,施工區界限內之現有行車道及行人路之部分路段或會分階段臨時封閉。 SECTIONS OF EXISTING CARRIAGEWAYS AND FOOTPATHS WITHIN LIMIT OF WORKS AREA MAY BE TEMPORARILY CLOSED IN PHASES AS AND WHEN REQUIRED.

圖例: LEGEND
原有部分 ORIGINAL

- 施工區界限 LIMIT OF WORKS AREA
- 行車道的行車線 (每一箭碼表示一條行車線) TRAFFIC LANE FOR CARRIAGEWAY (ONE ARROW REPRESENTS ONE LANE)
- 露天/於高架圍欄平台下/半開放式隔音罩下道路之建議路面水平(約數) PROPOSED ROAD LEVEL OF OPEN ROAD/ROAD UNDER ELEVATED LANDSCAPED DECK/ROISE SEMI-ENCLOSURE (APPROXIMATE)
- 行車隧道之建議路面水平(約數) PROPOSED ROAD LEVEL INSIDE ROAD TUNNEL (APPROXIMATE)
- 擬建之行人車道(連緊急行人通道) PROPOSED ROAD TUNNEL WITH EMERGENCY PEDESTRIAN WALKWAY
- 擬建之地面行車道 PROPOSED AT-GRADE CARRIAGEWAY
- 擬建之行人路 PROPOSED FOOTPATH
- 擬建之高架行車道 PROPOSED ELEVATED CARRIAGEWAY
- 擬建之中央分隔帶/安全島 PROPOSED CENTRAL RESERVE/REFUGE ISLAND
- 擬建之美化市容地帶 PROPOSED AMENITY AREA
- 現有政府前濱或海床將予臨時填平,以便興建行車隧道 EXISTING GOVERNMENT FORESHORE OR SEA-BED TO BE TEMPORARILY RECLAIMED FOR ROAD TUNNEL CONSTRUCTION
- 現有地面行車道將予臨時封閉及重建 EXISTING AT-GRADE CARRIAGEWAY TO BE TEMPORARILY CLOSED AND RECONSTRUCTED
- 現有地面行車道將予永久封閉及拆卸 EXISTING AT-GRADE CARRIAGEWAY TO BE PERMANENTLY CLOSED AND DEMOLISHED
- 現有高架行車道將予臨時封閉及重建 EXISTING ELEVATED CARRIAGEWAY TO BE TEMPORARILY CLOSED AND RECONSTRUCTED
- 現有高架行車道將予永久封閉及拆卸 EXISTING ELEVATED CARRIAGEWAY TO BE PERMANENTLY CLOSED AND DEMOLISHED
- 現有行人路將予永久封閉及拆卸 EXISTING FOOTPATH TO BE PERMANENTLY CLOSED AND DEMOLISHED
- 現有中央分隔帶/安全島將予重建 EXISTING CENTRAL RESERVE/REFUGE ISLAND TO BE RECONSTRUCTED
- 現有中央分隔帶/安全島將予拆卸 EXISTING CENTRAL RESERVE/REFUGE ISLAND TO BE DEMOLISHED
- 現有美化市容地帶將予重建 EXISTING AMENITY AREA TO BE RECONSTRUCTED
- 現有美化市容地帶將予拆卸 EXISTING AMENITY AREA TO BE DEMOLISHED
- 現有行人路將予臨時封閉及重建 EXISTING FOOTPATH TO BE TEMPORARILY CLOSED AND RECONSTRUCTED
- 擬建之行車隧道大體範圍 PROPOSED ROAD TUNNEL BUILDING AREA

工程名稱 Project title
 工務計劃項目第6579TH號
 中環及灣仔繞道和東區走廊連接路
 PWP ITEM NO. 6579TH
 CENTRAL - WAN CHAI BYPASS AND
 ISLAND EASTERN CORRIDOR LINK

圖則名稱 Plan title
 根據道路(工程、使用及補償)條例
 (第370章)而在憲報公布之圖則
 PLAN FOR GAZETTING UNDER ROADS
 (WORKS, USE AND COMPENSATION)
 ORDINANCE (CHAPTER 370)

圖則編號 Plan no. 92995/GAZ/1007A
 比例 scale A1: 1: 1000
 A3: 1: 2000

辦事處 Office
 主要工程管理處
 Major Works Project Management Office

路政署
 HIGHWAYS
 DEPARTMENT

DATE: 2009-5-4 11:55:52

Proposed Location of Real-time Noise Monitoring Stations

Tung Lo Wan Fireboat Station



Legend

 Proposed Location of the microphone

Causeway Bay Community Centre



Hong Kong Baptist Church Henrietta Secondary School

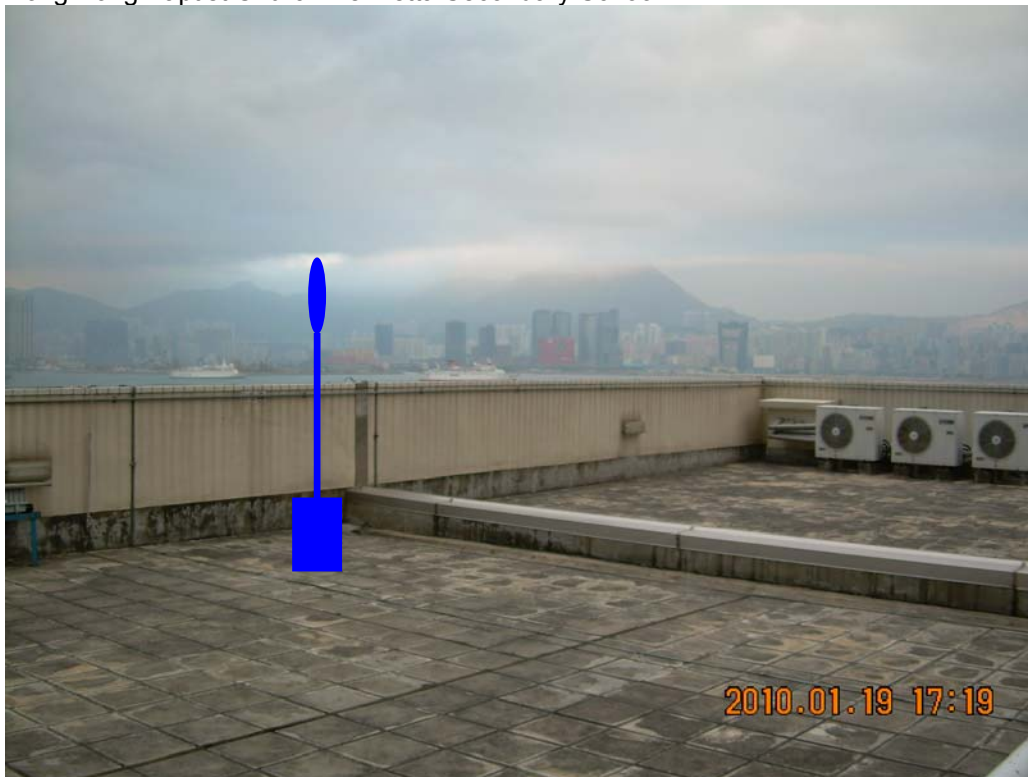

Legend

 Proposed Location
of the microphone

Oil Street Community Liaison Centre



Legend



Proposed Location
of the microphone

Appendix G
Construction Programmes
of Works Contracts



Project: MAN KWONG ST. J/O MAN YIU ST. BUS TERMINUS RELOCATION
 Date: 2010/5/25
 H= HIGHWAYS, A=AECOM, C=CHIU HING

任務		要徑任務進度		上顯型任務		上顯型進度		專案摘要	
任務進度		里程碑		上顯型要徑任務		分割		摘要群組	
要徑任務		摘要		上顯型里程碑		外部任務		期限	

Contract no. HY/2009/17

Contract Title : Central - Wan Chai Bypass - FEHD Whitfield Depot Re-provisioning Works

Works Schedule for the Advance Piling Works

ACTIVITY	Duration	START	FINISH	2010						2011
				July	August	September	October	November	December	January
<u>Submissions before Commencement of Piling Works</u>										
Notification of Commencement Date of Construction	1	16/7/2010	16/7/2010	◆						
Organization Chart of Environmental Management Team	1	16/7/2010	16/7/2010	◆						
Works Schedule	1	16/7/2010	16/7/2010	◆						
Location and Layout Plan	1	31/8/2010	31/8/2010			◆				
Construction Noise Management Plan	1	31/8/2010	31/8/2010			◆				
<u>Installation of Piles</u>										
Plants Set-up	7	24/9/2010	30/9/2010				■			
Installation of pipes E3b	70	2/10/2010	10/12/2010				■			
Installation of pipes E3a	60	2/10/2010	30/11/2010				■			
Installation of pipes E2a	60	12/10/2010	10/12/2010				■			
Installation of pipes E2b	70	14/10/2010	22/12/2010				■			
Testing	14	23/12/2010	6/1/2011						■	

HY/2009/18
Central - Wan Chai Bypass (Central Interchange)

